In The Fold

INSTALLATION GUIDE



TABLE OF CONTENTS

Wall-mount bracket installation

Tools required **1**
Instructions **1-2**

Storage dolly assembly

Tools required + parts included **3**
Instructions **4**

Ganging clip assembly

Instructions **5**

TOOLS REQUIRED

- A. Drill** for fastening & creating holes
- B. 1/2" Drill bit** for drilling holes with power drill
- C. Phillips head driver bit** for fastening with drill
- D. Wall-mounting hardware** appropriate for the wall condition

Compatible hardware includes:

- 1/4" truss head machine screws
- 5/16" pan head screws

NOTE: Mounting hardware is **not included** and must be selected based on the wall condition.

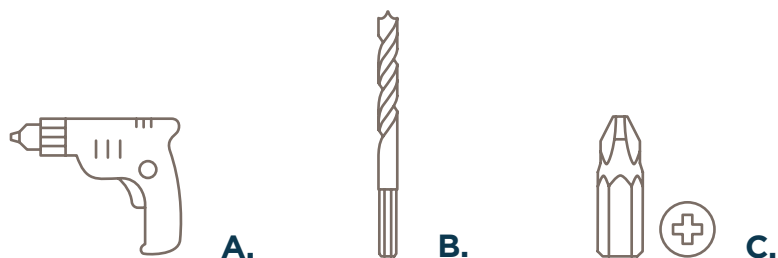

INSTALLATION INSTRUCTIONS

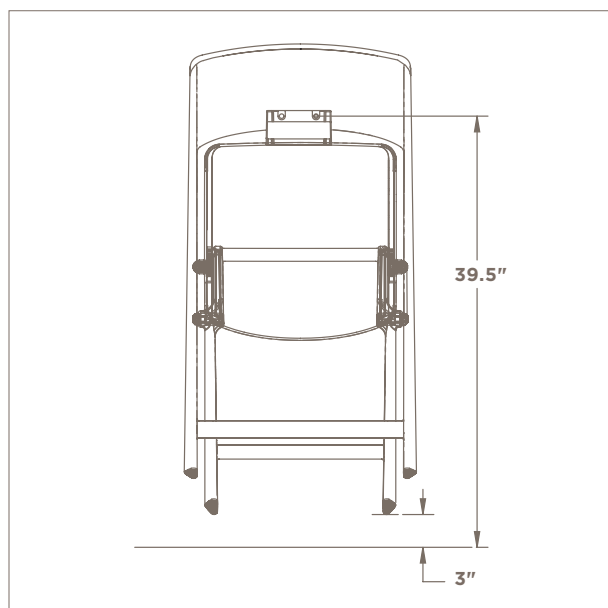

1. Select desired wall location. For recommended chair clearance, position mounting hardware 39.5" from the floor. This allows approximately 3" of clearance below the hanging chair.

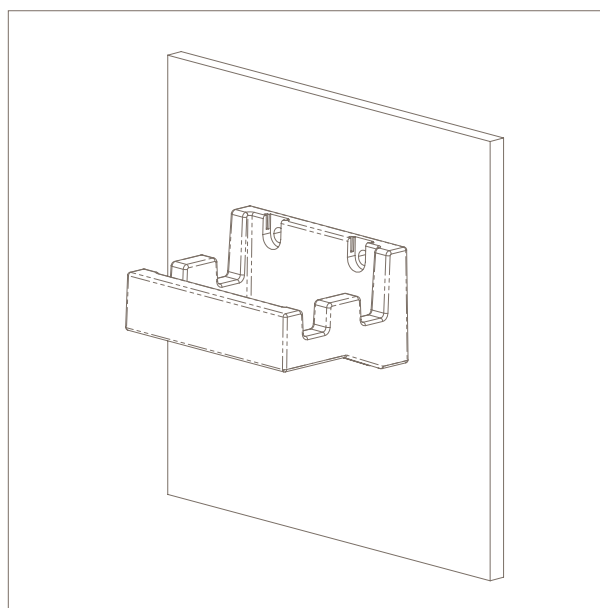

2. Hold the hanging bracket against the wall at the selected mounting location. Using the bracket as a guide, mark the two mounting hole locations on the wall.

INSTALLATION INSTRUCTIONS continued

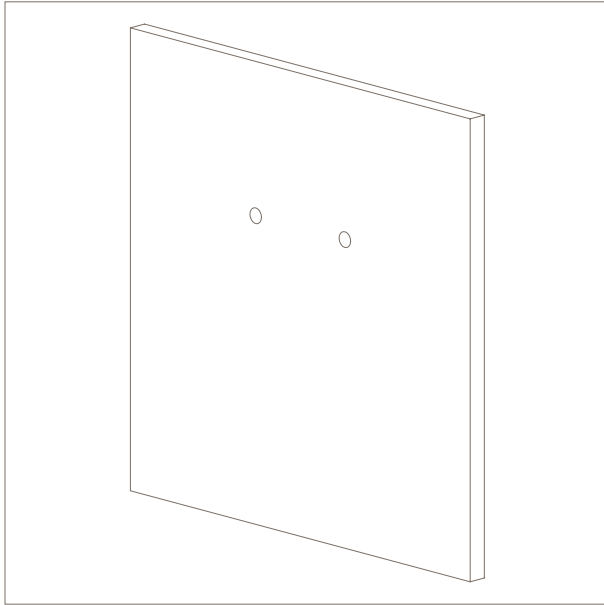

3. Using a power drill and appropriate drill bit, drill holes at the marked locations.

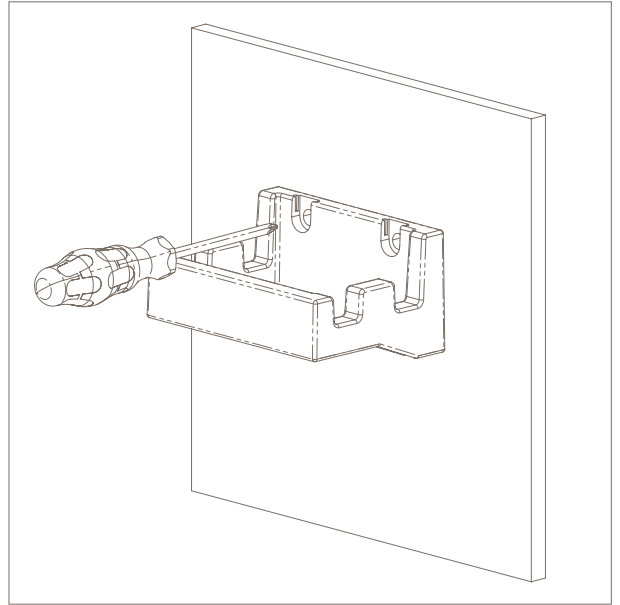

4. Reposition the hanging bracket over the drilled holes. Fasten the bracket securely to the wall using the selected wall-mounting hardware.

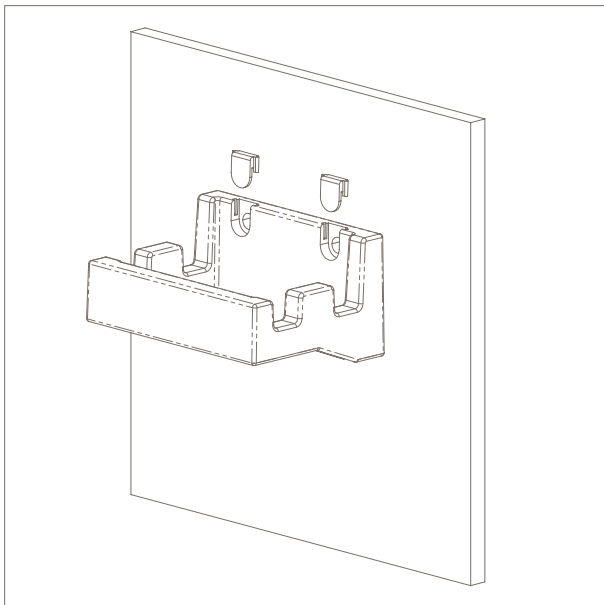

5. Install the two cover caps over the mounting hardware until fully seated.

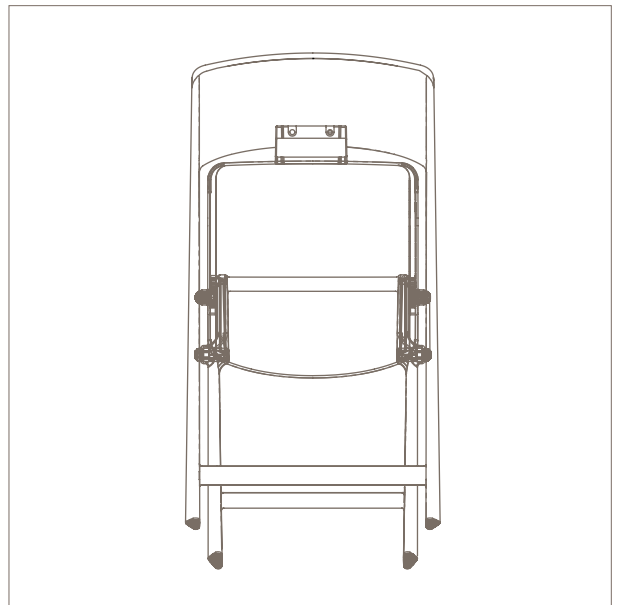

6. Confirm the hanging bracket is securely fastened to the wall before hanging the chair.

TOOLS REQUIRED

- A. Drill** for fastening & creating holes
- B. 1/2" Drill bit** for drilling holes with power drill
- C. Phillips head driver bit** for fastening with drill

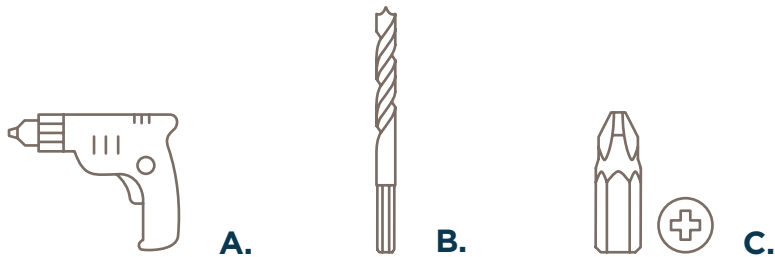

PARTS INCLUDED

- A. Side frames (2)**
- B. Casters (4)**
- C. Lower horizontal support tube (1)**
- D. Chair support rail (1 for single-tier dolly & 2 for double-tier dolly)**
- E. Caster support rails (2)**

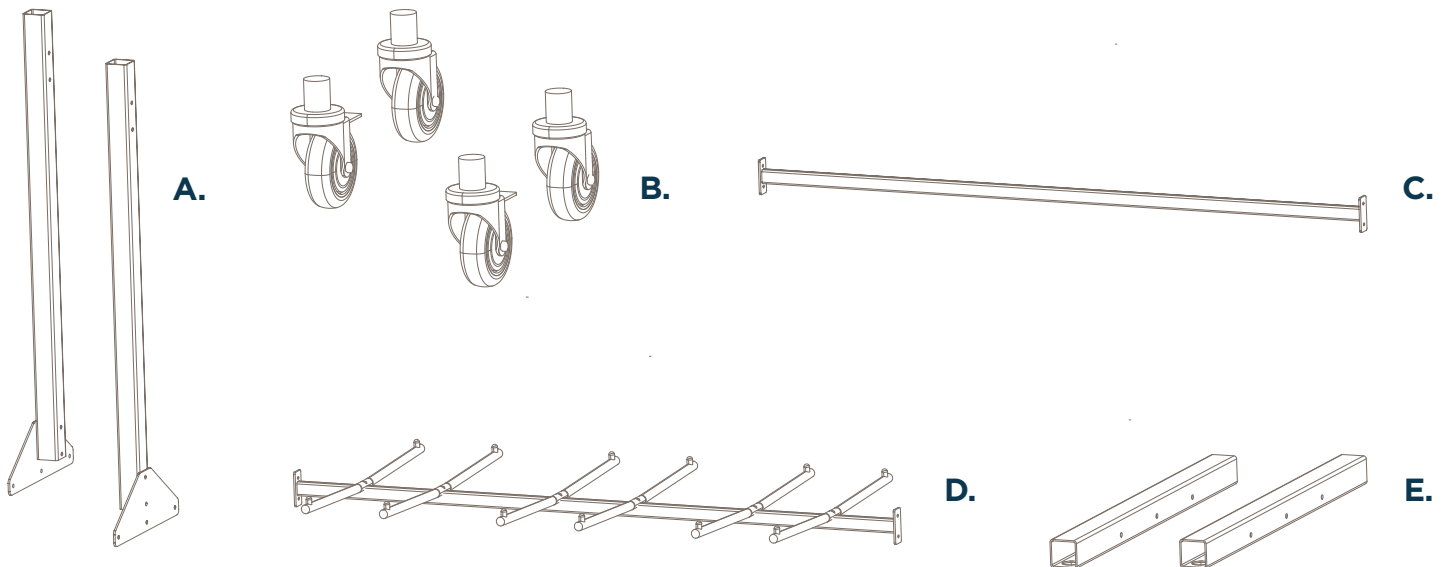

ASSEMBLY INSTRUCTIONS

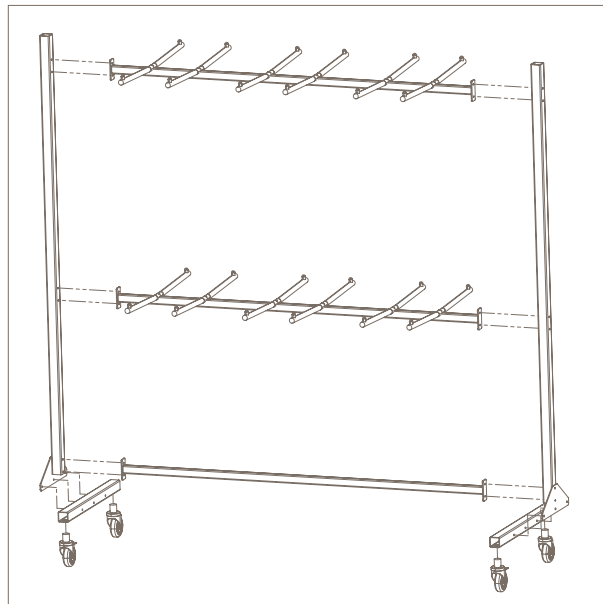

1. Place both side frames (A) with the mounting holes facing inward. Position one castor support tube (E) at the base of each side frame.
2. Insert the casters (B) into the open ends of the castor support tubes (E). Use a soft blow hammer to tap each caster into place until fully inserted.
3. Align each castor support tube (E) with the lower mounting holes on the corresponding side frame (A). Secure each castor support tube to the side frame using the included hardware.
4. Position the two side frames (A) upright and opposite one another. Place the lower horizontal support tube (C) between the side frames at the lower mounting position.
5. Align the ends of the lower horizontal support tube with the mounting holes on each side frame. Secure using the included hardware.
6. Position the chair support rail (D) between the two side frames (A). The angled support arms should extend outward from the dolly and angle upward to support the folded chairs. Align the ends of the chair support rail with the mounting holes on each side frame. Secure using the included hardware.
7. For the **two-tier dolly**, install the second chair support rail (D) at the upper mounting position between the two side frames. For the **one-tier dolly**, skip this step.
8. Once all parts are positioned and attached, tighten all hardware securely.

ASSEMBLY INSTRUCTIONS

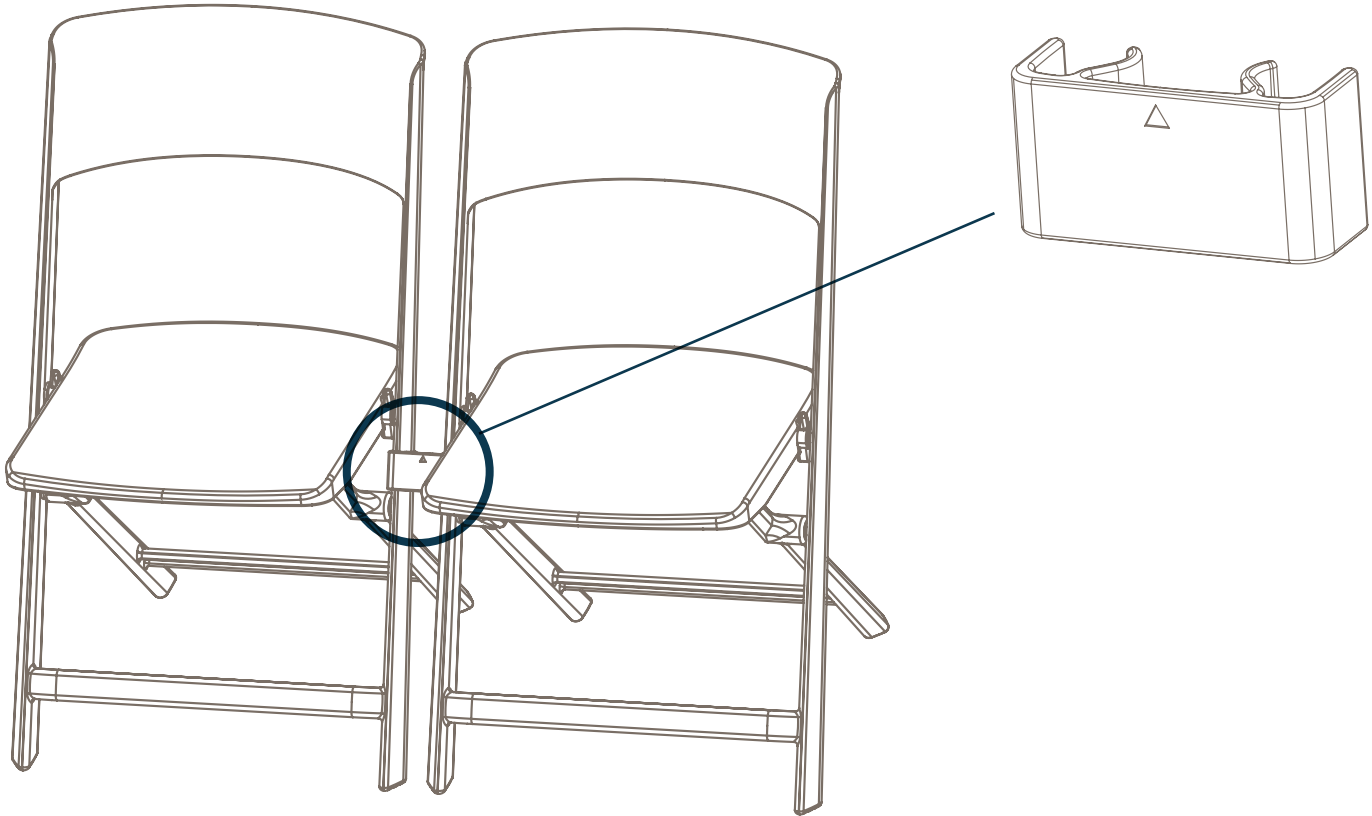

1. Unfold the chairs and place them in the desired finished location.
2. Position the chairs side by side so the leg sections are aligned and ready to be connected.
3. Hold the ganging clip with the indicator arrow facing upwards.
4. Snap the ganging clip onto each adjoining chair leg section underneath the seat mount.