

Kintra assembly





Table of contents

<u>Safety instructions</u>	3
<u>One piece top, no shelf assembly</u>	4-5
<u>One piece top, with shelf assembly</u>	6-7
<u>Two piece top, no shelf assembly</u>	8-9
<u>Two piece top, with shelf assembly</u>	10-11



Important safety instructions

When using an electrical furnishing, basic precautions should always be followed, including the following:

This furnishing is made for commercial use only.

Read all instructions before using this furnishing:

DANGER

To reduce the risk of electrical shock:

1. Always unplug this furnishing from the electrical outlet before cleaning.

WARNING

To reduce the risk of burns, fire, electric shock, or injury to persons:

1. Unplug from outlet before putting on or taking off parts.
2. Close supervision is necessary when this furnishing is used by, or near children, invalids, or disabled persons.
3. Use the furnishing only for its intended use as described in these instructions.
Do not use attachments not recommended by the manufacturer.
4. Never operate this furnishing if it has a damaged cord or plug, if it is not working properly, if it has been dropped or damaged, or dropped in water. Return the furnishing to a service center for examination and repair.
5. Keep the cord away from heated surfaces.
6. Do not use outdoors.
7. Use only SJT 18 AWG cord.
8. Risk of injury. Maximum load 75 pounds.

To reduce the risk of electric shock, this furnishing has a polarized plug (one blade is wider than the other). This plug will fit in a polarized outlet only one way. If the plug does not fit fully in the outlet, reverse the plug. If it still does not fit, contact a qualified electrician to install the proper outlet. Do not change the plug in any way.

Note – servicing is only to be performed by an authorized representative.

Servicing of double-insulated products

In a double-insulated product, two systems of insulation are provided instead of grounding. No grounding means is provided on a double-insulated product, nor is a means for grounding to be added to the product. Servicing a double-insulated product requires extreme care and knowledge of the system, and is to be done only by qualified service personnel. Replacement parts for a double-insulated product must be identical to the parts they replace. A double-insulated product is marked with the words “DOUBLE INSULATION” OR “DOUBLE INSULATED”. The symbol (square within a square) is also able to be marked on the product.

Save these instructions

One piece top, no shelf

SHIPPING

1. Images below show how units will be shipped

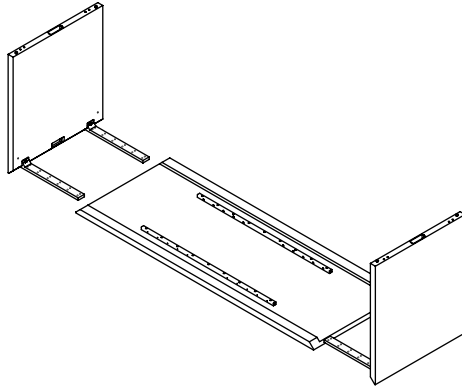

non-beam unit

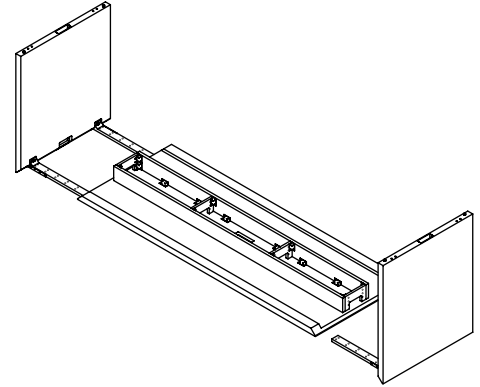

beam unit

STEP 1

1. Place top, face side down, on a non marring surface.

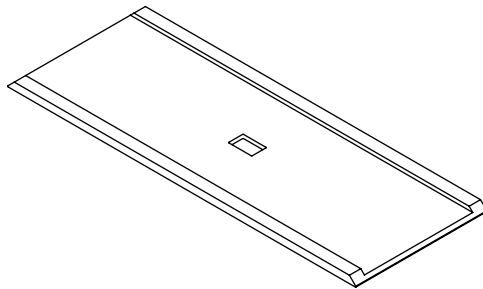

non-beam unit

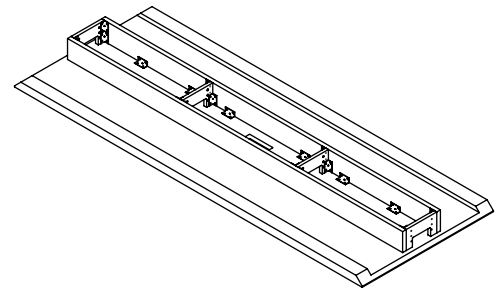

beam unit

One piece top, no shelf continued

STEP 2

Note: This step recommends the use of a bar type clamp to pull the end panels in snug to the top.

1. Connect end panels to top by pressing mitered edge of end panel to the mitered edge of top. Ensure that mitered seam is tight and the end panel bottom edge is aligned along the bottom edge of the miter by using firm pressure when pressing end panel to surface
2. Use 1 ½" screws from HK-212 to secure the end panel internal leg assemblies to the top.
3. Non-beam units, move to step 3. For beam units, secure the beam assembly end panel to the end panel of the unit using 2" screws from HK-102

Note: Match end panel to correct end of top as marked. Example: A to A & B to B

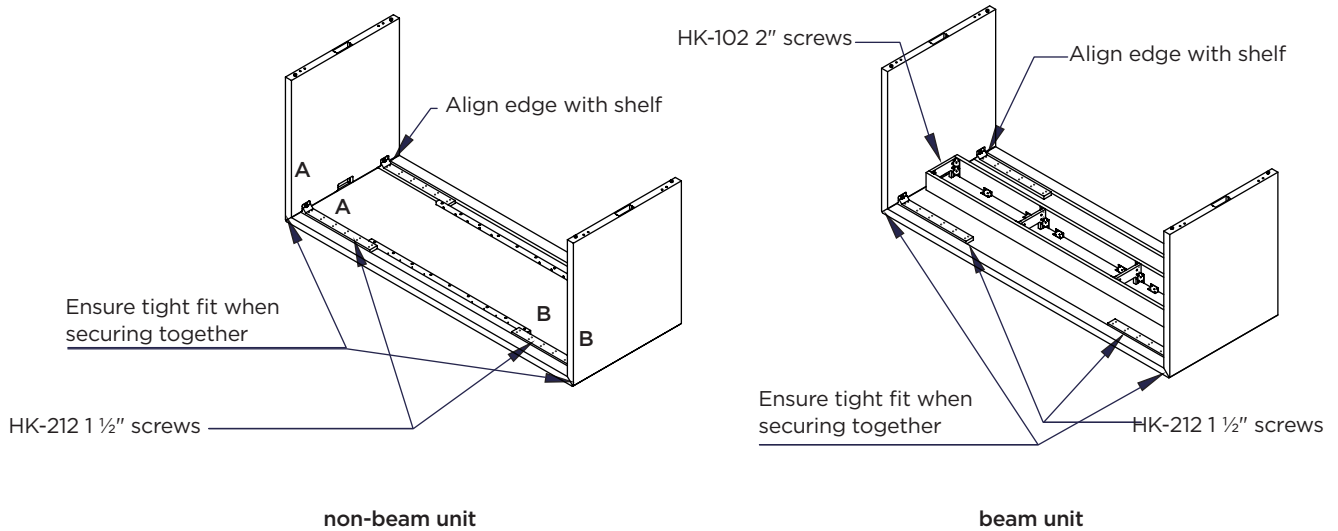

STEP 3

1. Unit can now be flipped right side up and placed in desired location

One piece top, with shelf

SHIPPING

1. Images below show how units will be shipped

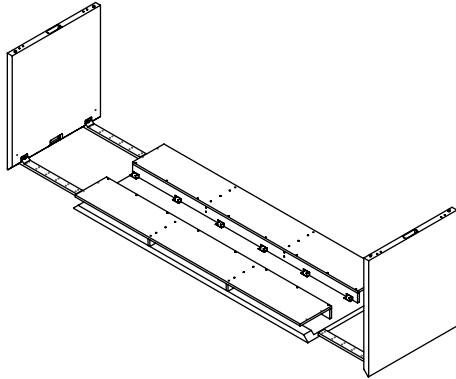

non-beam unit with shelf

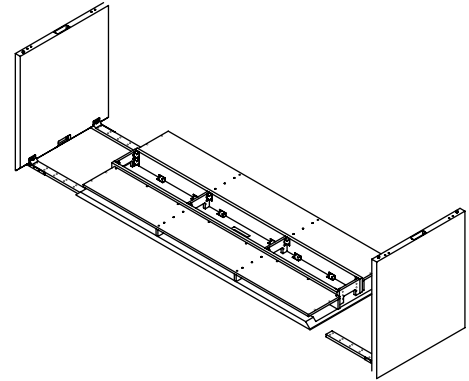

beam unit with shelf

STEP 1

1. Place top, face side down, on a non marring surface.
2. Remove shipping screws from the shelf bottom and along the back edge, set to the side.

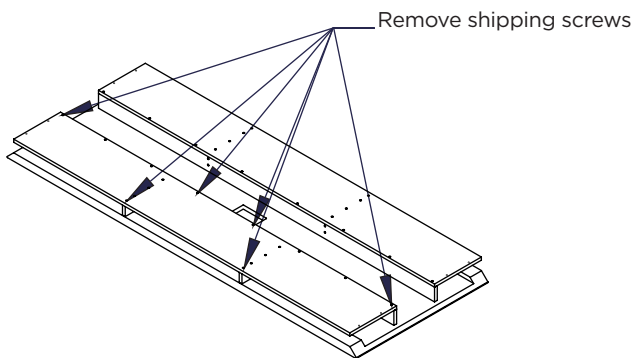

non-beam unit with shelf

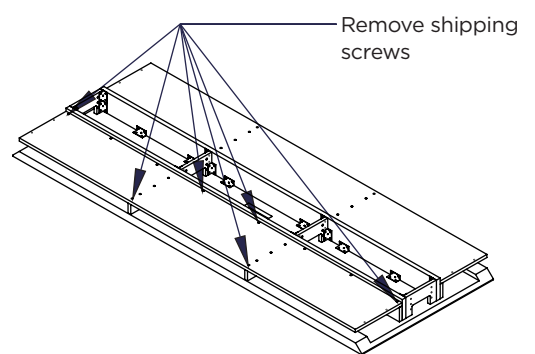

beam unit with shelf

One piece top, with shelf continued

STEP 2

Note: This step recommends the use of a bar type clamp to pull the end panels in snug to the top.

1. Connect end panels to top by pressing mitered edge of end panel to the mitered edge of top. Ensure that mitered seam is tight and the end panel bottom edge is aligned along the bottom edge of the miter by using firm pressure when pressing end panel to surface
2. Use 1 1/2" screws from HK-212 to secure the end panel internal leg assemblies to the top.
3. **Non-beam units, move to step 3.** For beam units, secure the beam assembly end panel to the end panel of the unit using 2" screws from HK-102

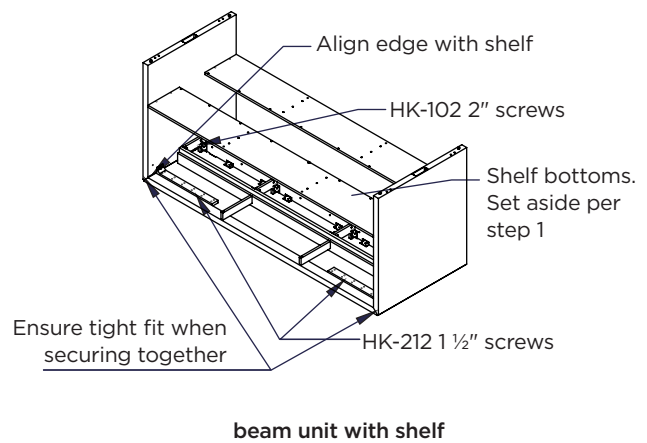
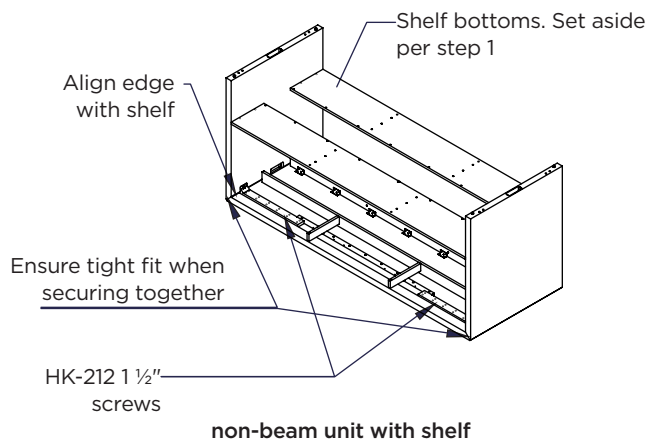

STEP 3

1. Replacing the shelf assembly
 - a. Remove the 1 1/2" outer screws of the divider panels and discard.
 - b. Replace the shelf bottom onto the dividers. Center the dividers with the holes in the shelf bottom, use HK-15, 1 1/2" screws to re-attach.
 - c. Install 2" screws into the shelf divider outer holes using HK-92.
 - d. Using shelf pins from HK-134. Insert pins in pre-drilled hole in end panel of unit to locate the proper height of the shelf bottom. Using HK-35, secure end panel to shelf bottom with 1/2" L-brackets. Shelf bottom will have pre-drilled location holes showing where to place brackets.
2. Unit can now be flipped right side up and placed in desired location

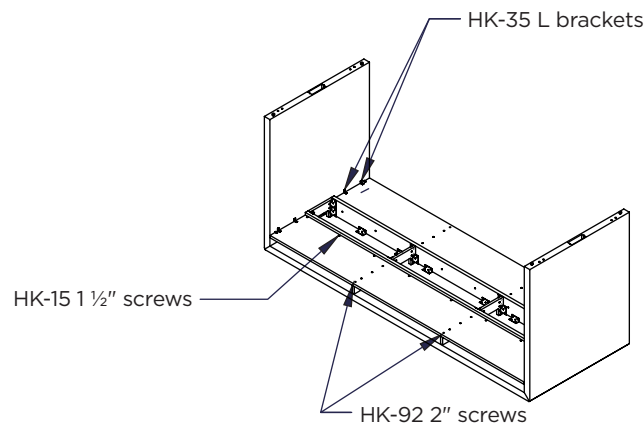

Two piece top, no shelf

SHIPPING

1. Images below show how unit will be shipped

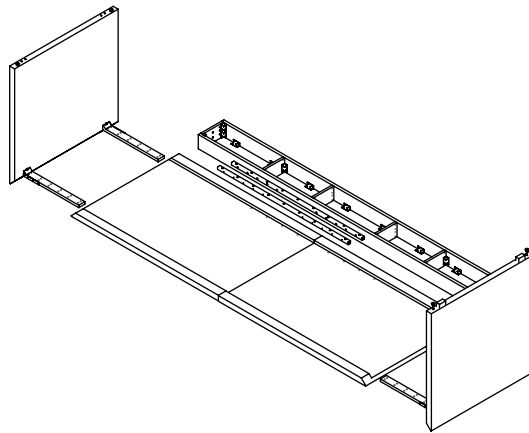

STEP 1

1. Place two piece top, face side down, on a non marring surface.
2. Install clamp plates from HK-6. While pulling both sections together making sure the seam is tight, center the 4x4 plates over the seam and use the screws provided to attach. Use caution not to locate plates where the long beams of the beam assembly will sit onto the top.
3. Using $\frac{3}{4}$ " screws from HK-37, attach 1" square tube supports along inside of the under frame rail of the top. Use pre-drilled location holes to locate.

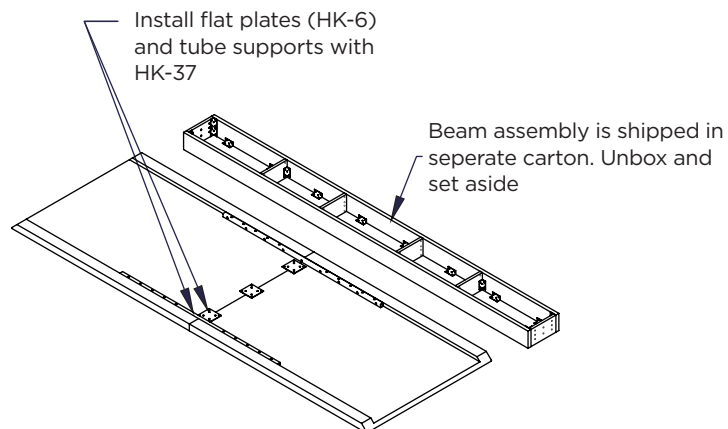

Two piece top, no shelf continued

STEP 2

Note: This step recommends the use of a bar type clamp to pull the end panels in snug to the top. Set the beam assembly onto the top. Do not attach at this time.

1. Connect end panels to top by pressing mitered edge of end panel to the mitered edge of top. Insure that mitered seam is tight and the end panel bottom edge is aligned along the bottom edge of the miter.
2. Use 1 ½" screws from HK-212 to secure the end panel internal leg assemblies to the top.
3. Center the beam unit on the top. Using ¾" screws from HK-37 attach the beam assembly to the top utilizing the pre attached L-brackets.
4. Secure the beam assembly end panel to the end panel of the unit using 2" screws from HK-102

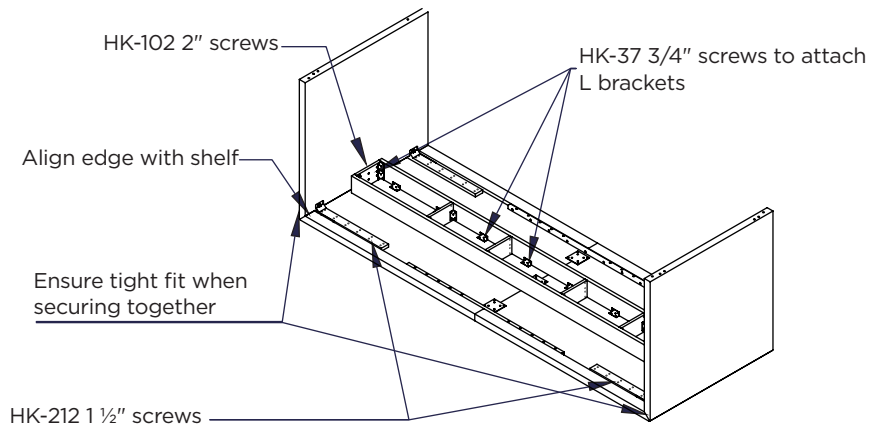

STEP 3

1. Unit can now be flipped right side up and placed in desired location

Two piece top, with shelf

SHIPPING

1. Images below show how unit will be shipped

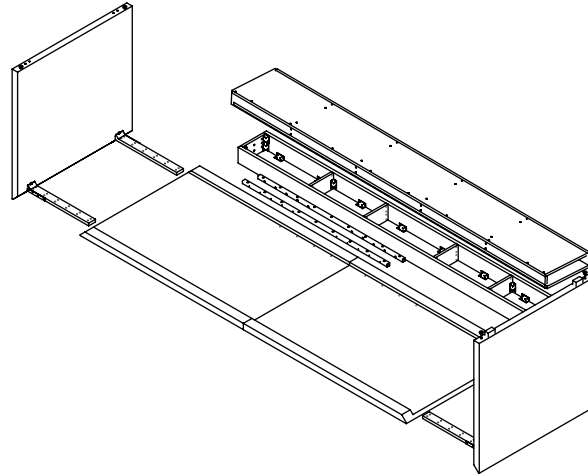

STEP 1

1. Place top, face side down, on a non marring surface.
2. Install clamp plates from HK-6. While pulling both sections together making sure seam is tight, center the 4x4 plates over the seam use screws provided to attach. Use caution not to locate plates where the long beams of the beam assembly will sit onto the top.
3. Using $\frac{3}{4}$ " screws from HK-37 attach 1" square tube supports along the inside of the under frame rail of the top. Use pre-drilled location holes to locate.

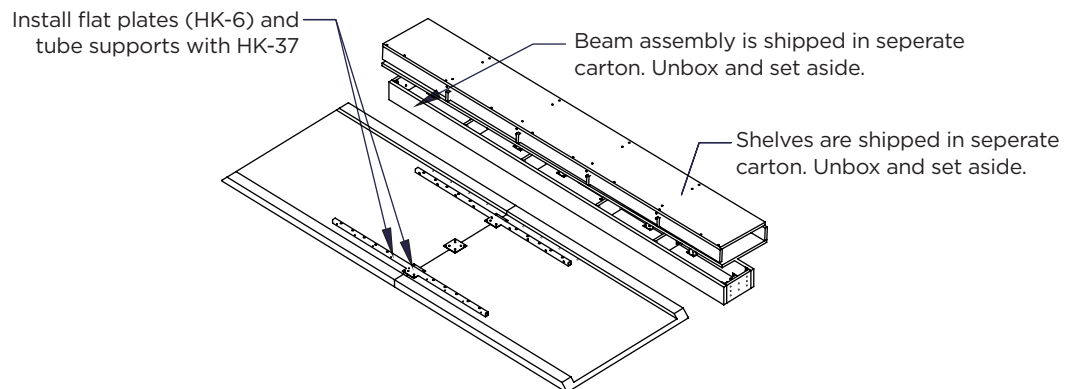

Two piece top, with shelf continued

STEP 2

Note: This step recommends the use of a bar type clamp to pull the end panels in snug to the top. Set the beam assembly onto the top. Do not attach at this time.

1. Connect end panels to top by pressing mitered edge of end panel to the mitered edge of top. Insure that mitered seam is tight and the end panel bottom edge is aligned along the bottom edge of the miter.
2. Use 1 1/2" screws from HK-212 to secure the end panel internal leg assemblies to the top.
3. Center the beam unit on the top. Using 3/4" screws from HK-37 attach the beam assembly to the top utilizing the pre attached L-brackets.
4. Secure the beam assembly end panel to the end panel of the unit using 2" screws from HK-102

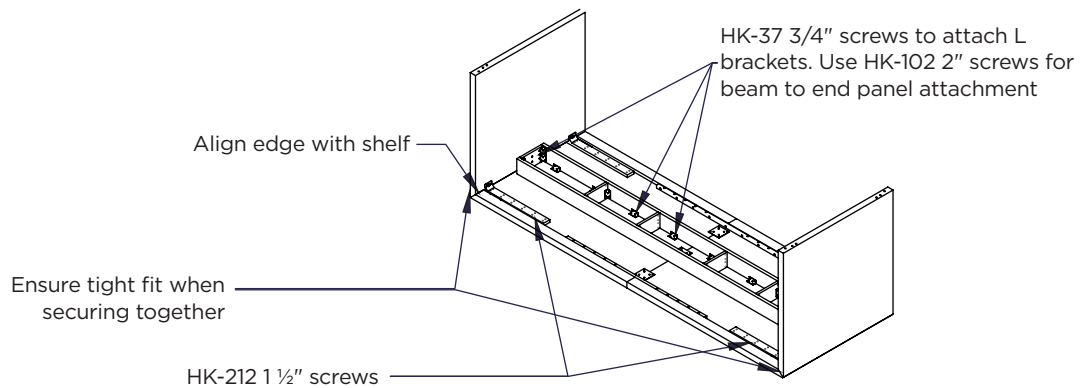

STEP 3

1. Intalling the shelf assemblies
 - a. The shelf assemblies for 2 pc units are shipped in their own packaging or secured as separate pieces with the tops and beams.
 - b. Place a shelf assembly on each side of the beam assembly.
 - c. Secure the back panel of the shelf assembly to the beam rail using 1 1/2" screws from HK-15 through the pre-drilled holes in the beams into the back of shelf assembly.
 - d. Install 2" screws into the shelf divider outer holes using HK-92.
 - e. Using shelf pins from HK-134. Insert pins in pre-drilled hole in end panel of unit to locate the proper height of the shelf bottom. Using HK-35, secure end panel to shelf bottom with 1/2" L-brackets. Shelf bottom will have pre-drilled location holes showing where to place brackets.
2. Unit can now be flipped right side up and placed in desired location

