

Applause assembly





Table of contents

Static base	3
Folding base	4
Modesty - fixed	5
Modesty - removeable	5
Modesty - hinged	6

Static base assembly

Tools required:

- Cordless driver or impact driver

1. Lay table top finished side down so screw holes are facing up and place legs on either side of table (**Figure A**)
2. Place one of the legs on the left or right side of table aligning holes in base plate with holes in table (**Figure B**)
3. Use 8x #12 X 1" Phillips pan head screws with the cordless driver to secure legs to top

Repeat steps 2-3 for other leg

4. Carefully flip table over to use

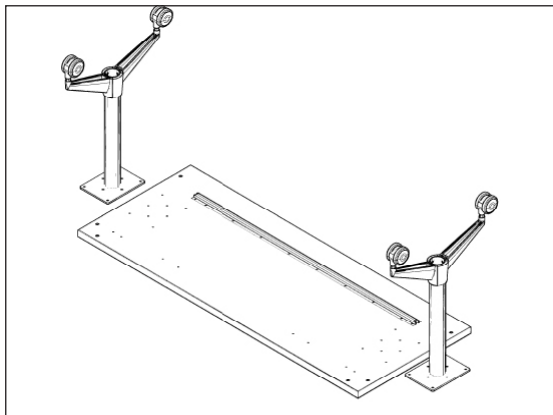

Figure A

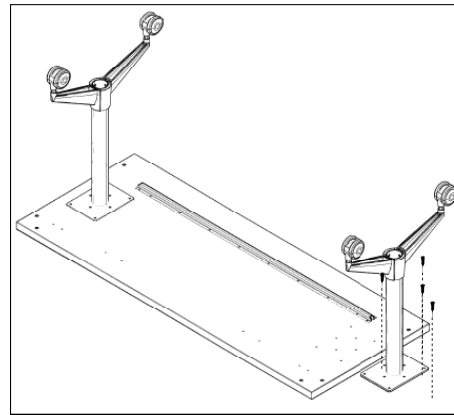

Figure B

#12 X 1" phillips pan head screw

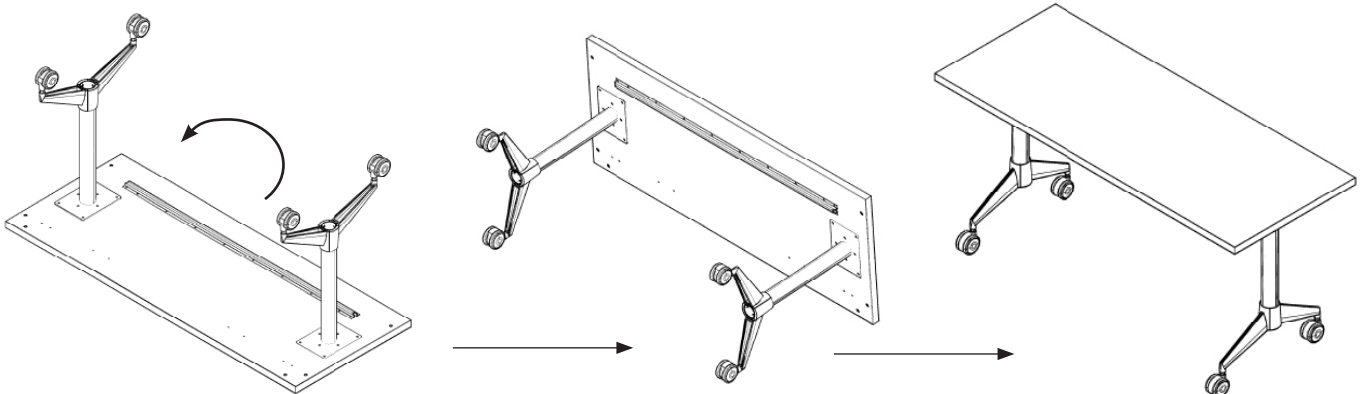

Figure C

Folding base assembly

Tools required:

- Cordless driver or impact driver

1. Align holes in four corners of base mount plate with four outer pre-drilled holes. **Note:** Release lever should face the end of the table.
2. Secure in place with 10 screws per base.

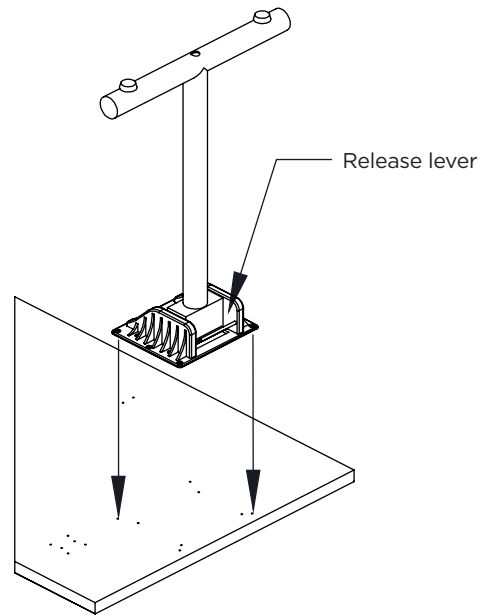

Modesty - Fixed

1. Align holes on modesty brackets with pre-drilled holes on bottom of worksurface.
2. Attach fixed modesty panel to top by using two #10x5/8" screws per bracket.

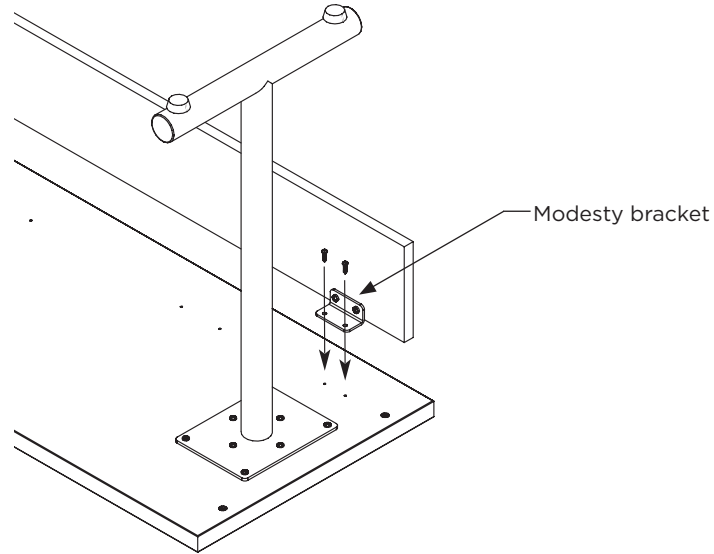

Modesty - Removeable

1. Align holes on bracket clamps with pre-drilled holes on bottom of worksurface. Open side of bracket clamp should face modesty panel.
2. Attach brackets clamps to top by using two #10x5/8" screws per bracket clamp
3. Slide modesty brackets into bracket clamps and secure by tightening thumb screws.

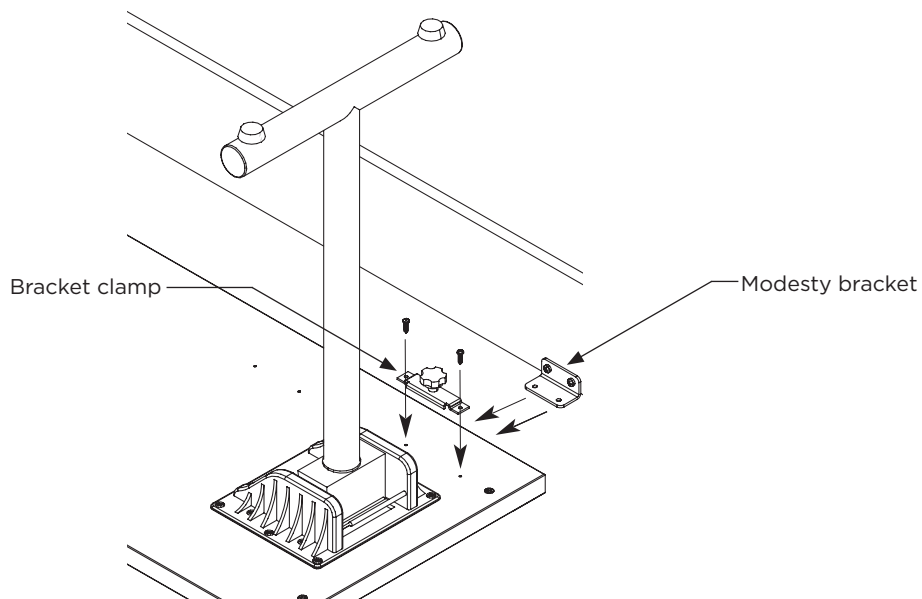

Modesty - Hinged

1. Align holes on hinged modesty brackets with pre-drilled holes on bottom of worksurface.
2. Attach hinged modesty panel to top by using two #10x5/8" screws per bracket.

