

Aptos assembly





Table of contents

Duofoil legs	3
Trifoil column	4
Elevated runoff top	5-6
Duofoil standoffs	7
End panel	8
Height adjustable credenza	9-10
Height adjustable peninsula desk	11-12
Modular pedestals	13-14
Wallmount storage / tackboards	15
Worksurface storage	16
Edge mount privacy panels	17
Surface mount privacy screens	18
Open plan benching	19-21

Duofoil legs installation instructions

Tools required

- Drill
- Tape measure
- 1/8" drill bit

1. Check bottom side of top for pre-bored mounting holes. (If done, move to Step 4.)
2. If top ordered does not have pre-bored mounting holes, place top upside down on a protective surface and locate duofoil standoffs at 45° angle to edge of top with wire cavity facing toward kneespace at distance of 8 5/8" from edge of top to the center of the mounting plates back edge (see illustration below) and mark location of each hole using mount place holes as location guide.
3. After marking mounting plates hole location, remove duofoil legs and pre-bore 1/8" diameter x 1 3/16" deep holes at previously marked locations.
4. Attach duofoil legs to bottom side of top (wire cavity facing kneespace) with HK-71, aligning holes in mount plate with pre-bored holes in top.
5. Leveler in bottom of duofoil legs can be adjusted out, up to 1", to level the top as needed.

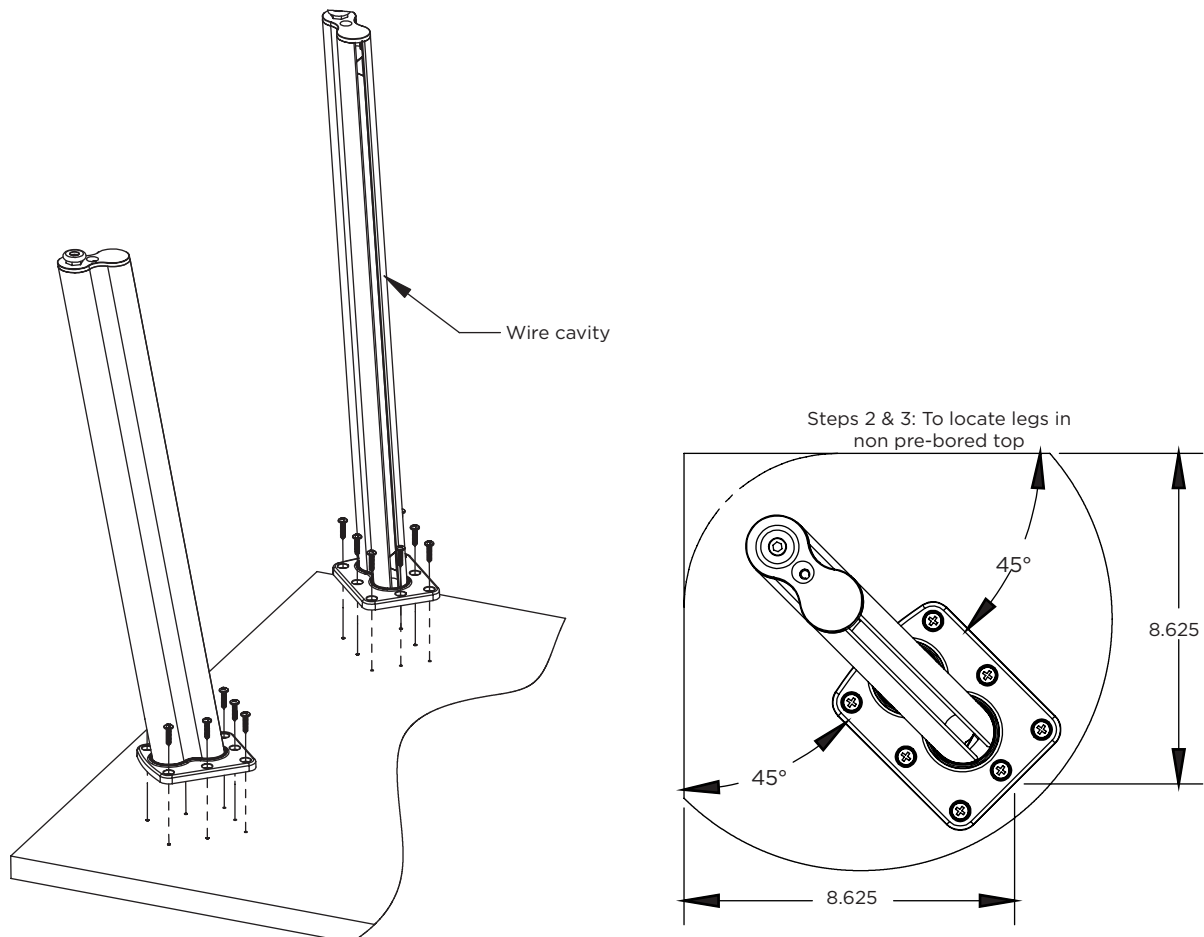

Trifoil column installation instructions

Tools required

- Drill
- Tape measure
- 1/8" drill bit

1. Check bottom side of top for pre-bored mounting holes. (If done, move to Step 4.)
2. If top ordered does not have pre-bored mounting holes, place top upside down on a protective surface and locate trifoil column in desired location centered in top depth and no more than 18" from end of top to center of column and mark location using mounting plate holes as location guide.
3. After marking mounting plates hole location, remove trifoil column and pre-bore 1/8" diameter x 1 3/16" deep holes at previously marked locations.
4. Attach trifoil column to bottom side of top with HK-98, aligning holes in mount plate with pre-bored holes in top.
5. Leveler in bottom of trifoil column can be adjusted out, up to 1", to level the top as needed.

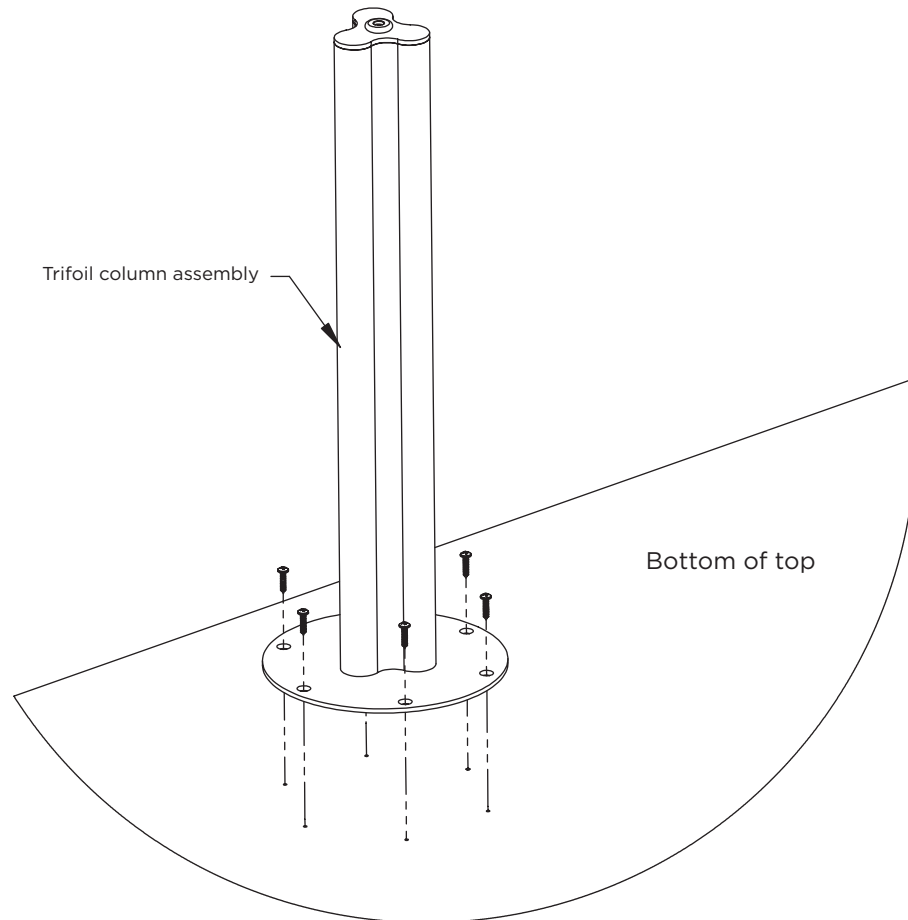

Elevated runoff top

1. With top upside down on a protective surface install both duofoil standoffs and the runoff support (trifoil column duofoil legs, runoff end panel) using the instructions & hardware supplied with each item.
2. Aligning the holes in the mounting plates with the pre-bored holes in the top. Position the wire cavity so that it faces the knee space of the top.
3. The duofoil pieces will be rotated at a 45° angle.
4. Measure the center to center distance of the mounting studs om the duofoil standoffs.
5. This measurement will be used to bore the mounting holes in the top of the low height cabinet in the next step.

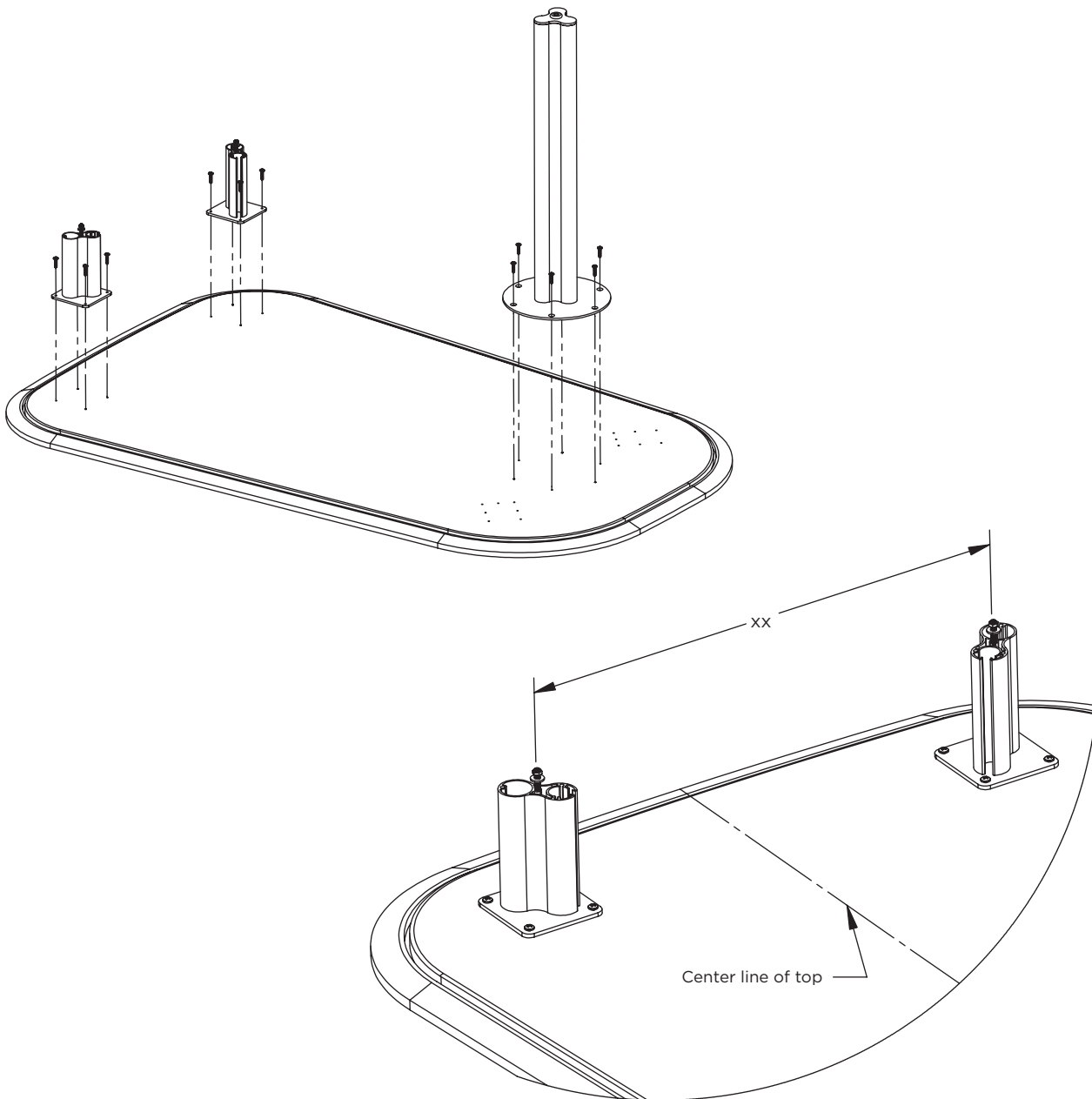

Elevated runoff top, continued

6. Determine application (open plan or private office), open plan is located 3.5" off front edge of cabinet, private office is located 9" off the back edge of the cabinet.
7. Locate desired placement side to side on the low height cabinet and mark the center line location of the elevated runoff top.
8. Divide the C-C measurement previously taken from the standoffs on the elevated runoff top and divide it by 2.
9. Measure this distance both ways from the top center line along with the front to back dimension (3.5" or 9") depending on the application to find center points of the standoffs.

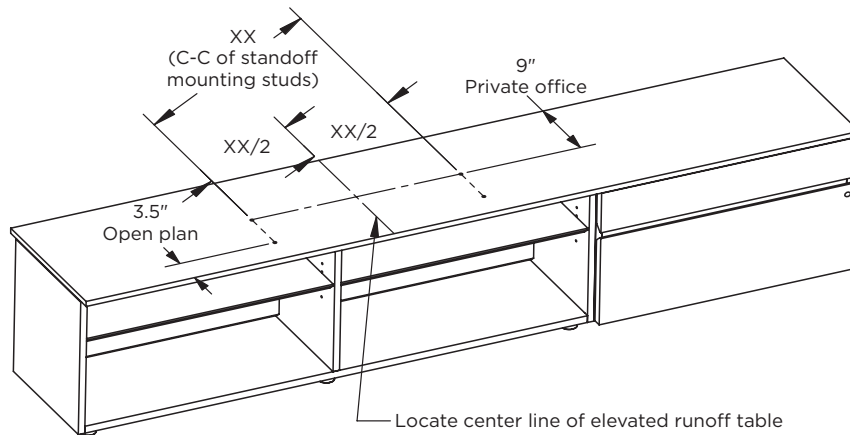

10. Verify that the marked locations of the standoff mounting holes are not located over a divider panel or end panel. If they are, shift location of top to clear obstructions.
11. Tape off area to be drilled to help protect the finished surface. Center punch the 2 location holes to the bored.
12. Bore the 2 mounting holes for the standoffs using a 3/8" drill bit thru the top of the low height cabinet.
13. Remove tape and carefully install the elevated runoff top being careful not to scratch the finished top surface of the low height cabinet when placing the studs into the bored holes.
14. Once the elevated runoff top is placed, secure it with the washer and nut supplied with the standoffs.
15. Level top with the adjustable leveler in the runoff end support.

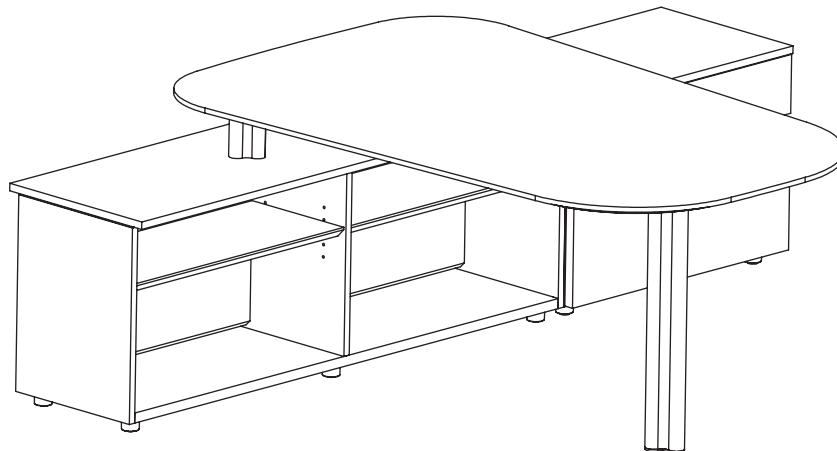

Duofoil standoffs

Note: Tops require two standoffs at each elevated end

Tools required

- Drill
- Tape measure

Elevated runoff tops:

1. On a protective surface, place top upside down.
2. Position the standoff at a 45° angle to keep the edge of the top with the wire cavity slot facing toward the kneespace, align holes in the mount plate with the pre bored holes in the top and attach using HK-31.
3. Repeat the above two steps for remaining standoffs.

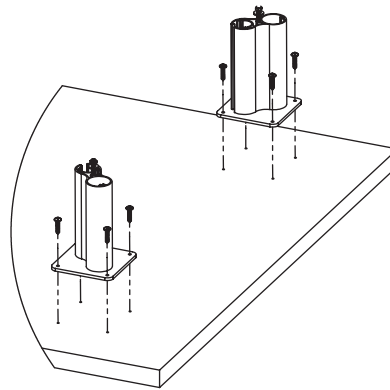

Modular tops:

1. On a protective surface, place top upside down.
2. Position the standoff at a 45° angle to keep the edge of the top with the wire cavity slot facing toward the kneespace. See diagram to the right for locations.
(Note: The edge of the mounting plate will be parallel with the edge of top)
3. With the standoff in the correct position, attach using HK-31 (No pre boring needed).
4. Repeat the above three steps for remaining standoffs.

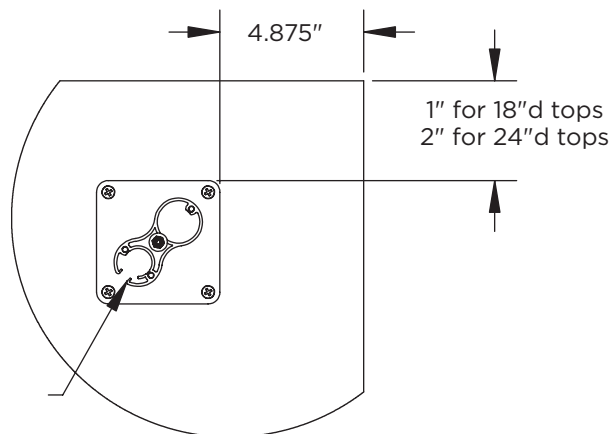

End panel

1. With top upside down on a protective surface, place end panel assembly on top as shown (centered side-to-side).
2. Inset $\frac{1}{8}$ " from outer end of top and attach with HK-98.

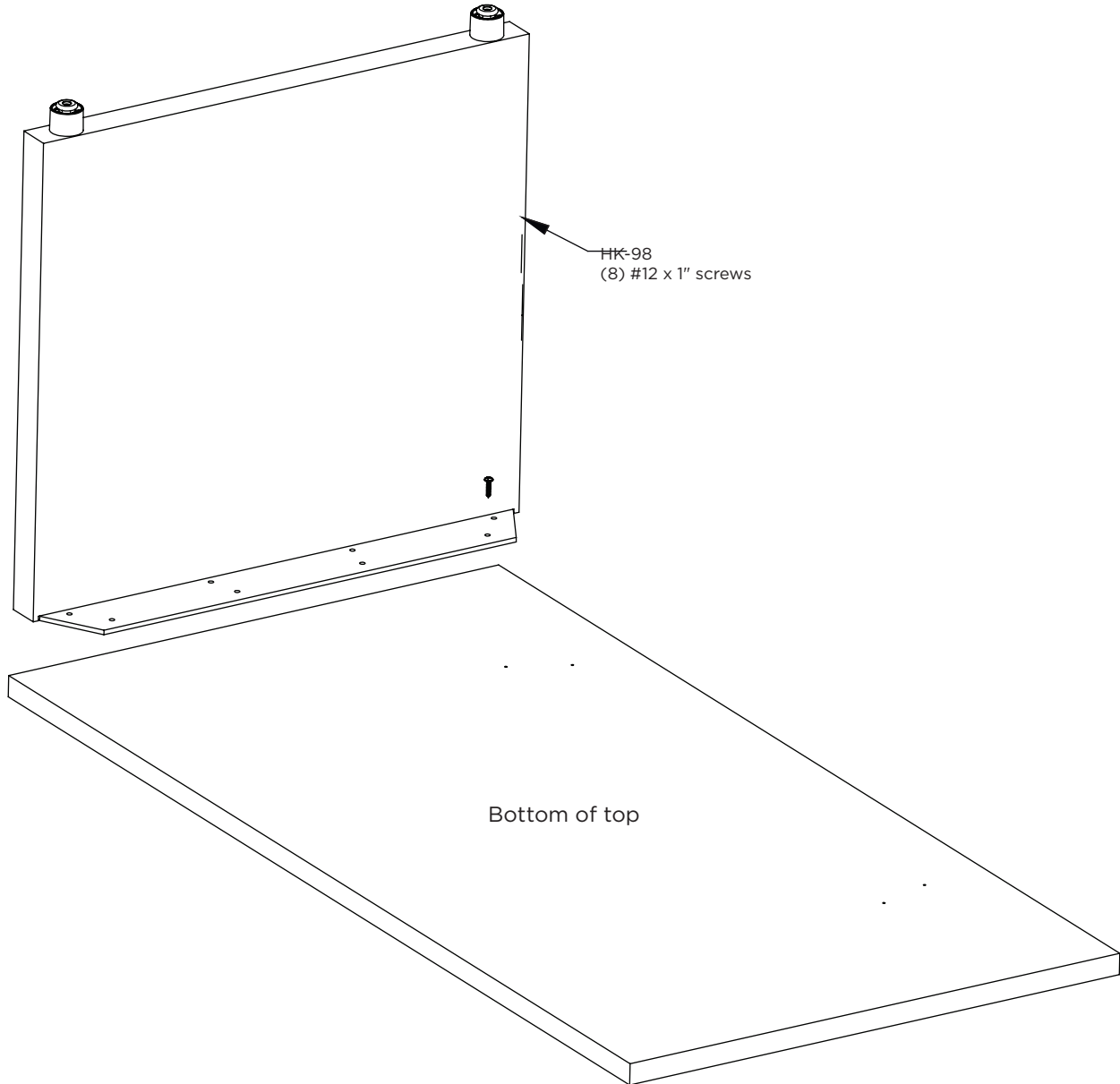

Height adjustable credenza

Note: Unit will not stand on its own once assembled. Must be connected to a ped or end panel at both ends (18"D minimum).

1. Place top upside down on a protective surface.
2. Install the control box with HK-92 and control switch with 2 screws from HK-83 aligning with pre-bored holes. (Switch can be mounted on left or right side of top.)
3. Position base upside down on top and align holes in mount plates with pre-bored holes in top. (Stabilize the base through the next step until secured to the top.)
4. Connect each, lift column to the control box using one control cable, then insert into control box and plug into a power source.
5. Press the down arrow button on the control switch to synchronize the lift columns. Press the up arrow on the control switch to raise the base approx. 10" allowing access to the mounting plates.
6. Attach the base to the top using HK-71 through the mounting plates aligning with the pre-bored holes in the top.
7. Use the remaining screws from HK-83 along with the cord clips and one wraps to clean up and secure wires underneath the top as desired.

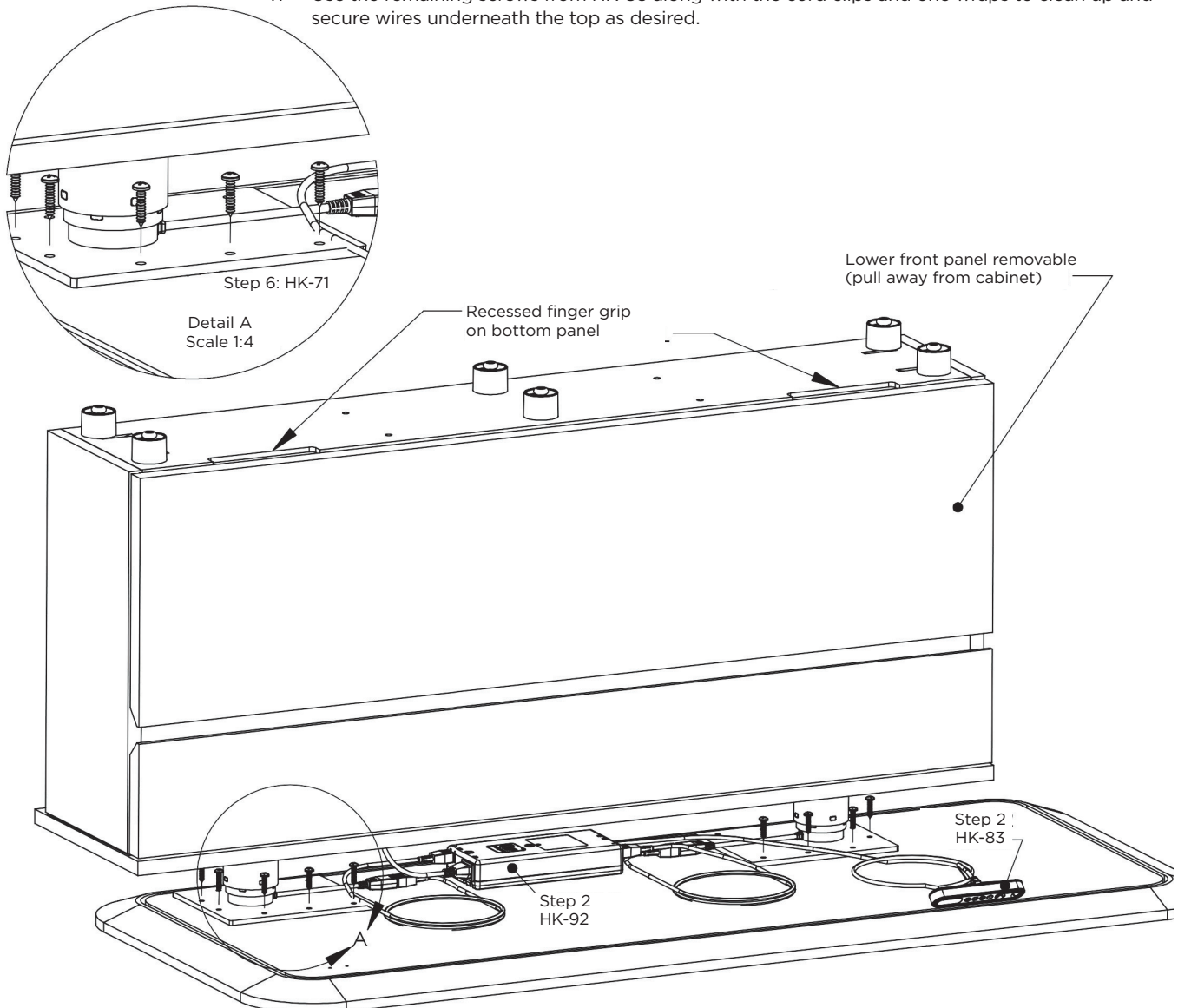

Height adjustable credenza attaching to adjoining cabinet

Note: Height adjustable credenza will not stand on its own. Stabilize cabinet at all times until secured to adjoining cabinets. Credenza must have a cabinet or end panel minim 18"D attached on each side for stability.

1. Remove lower face panel of height adjustable credenza (pulling away from cabinet) using machined finger grips on bottom of cabinet.
2. Pre-bore minimum of four .125" diameter holes in both end panels of height adjustable credenza from inside of cabinet.
3. Align height adjustable credenza cabinet with adjoining cabinet and level. Once level and aligned, insert 4 # 8 x 1.25" wood screws in pre-bored holes. Repeat for cabinet on opposite side of height adjustable credenza.

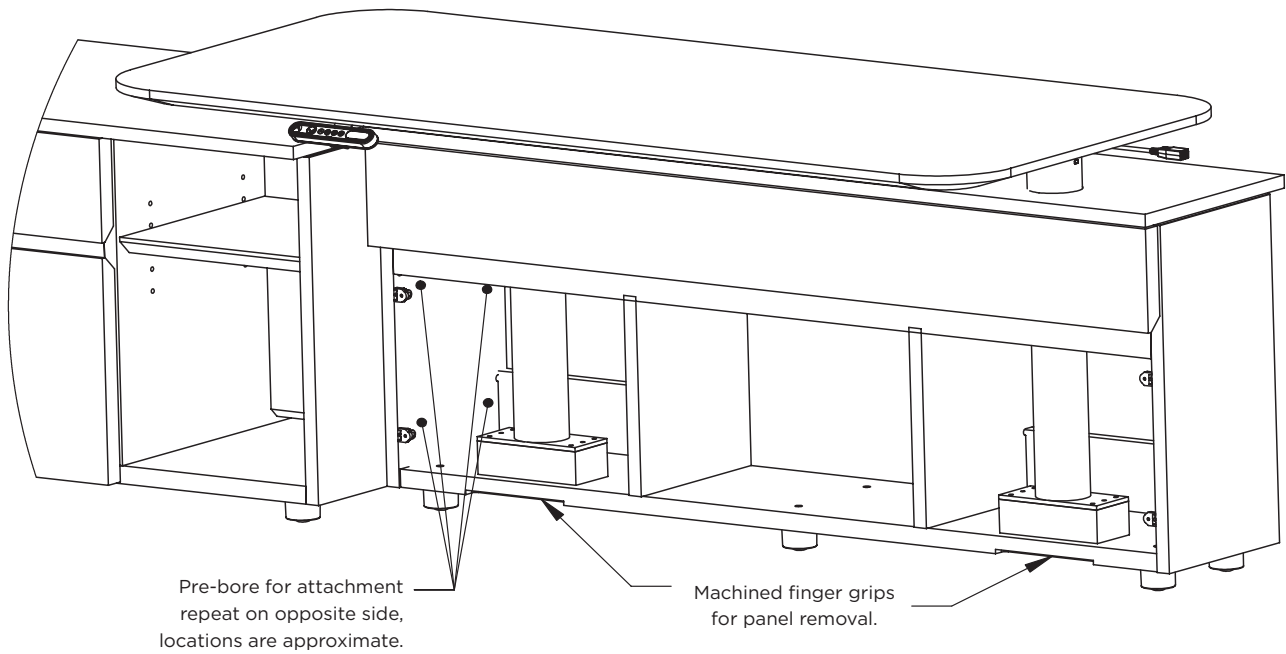

Height adjustable peninsula desk

Tools required

- Drill
- 4mm Allen wrench

Note: 2 person install

1. Locate wall cabinet in desired location and level. Remove screws from adjustable shelf clips for access to flip down back panel in open storage area. (The lower front of the lift column cavity is removable by pulling panel away from the cabinet.)
2. Remove mount plate on runoff base and rotate 90° from shipping position to assembly position as shown and re-attach.

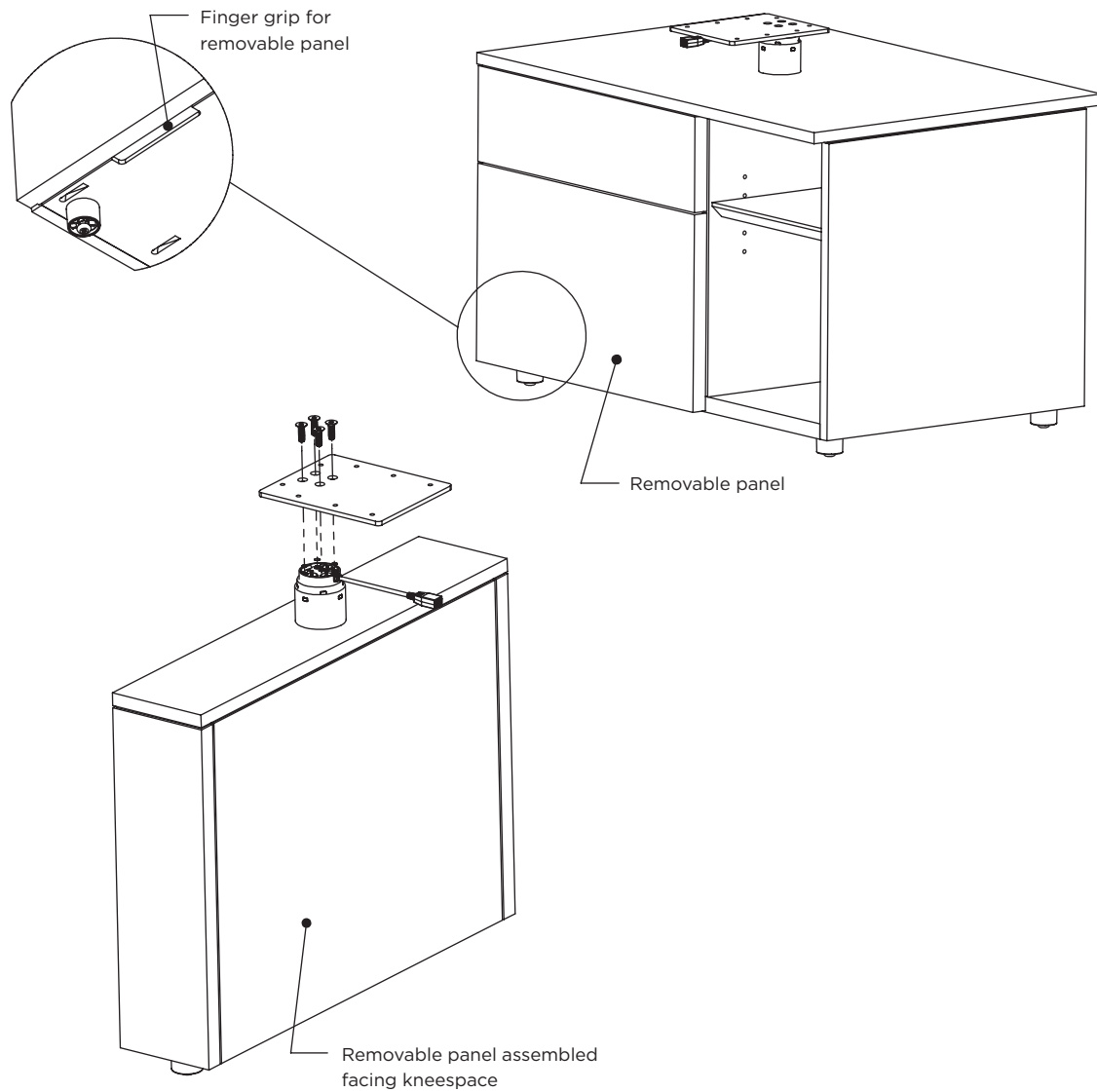

Height adjustable peninsula desk, continued

3. With worksurface upside down on a protective surface, install the control box with HK-92.
4. Attach the control switch with HK-83. (Use remaining screws in kit to secure wires at the end of assembly process.)
5. Locate runoff base assembly over pre-bored hole locations in top and attach using HK-71. (Only 4 holes will be accessible during this step.)

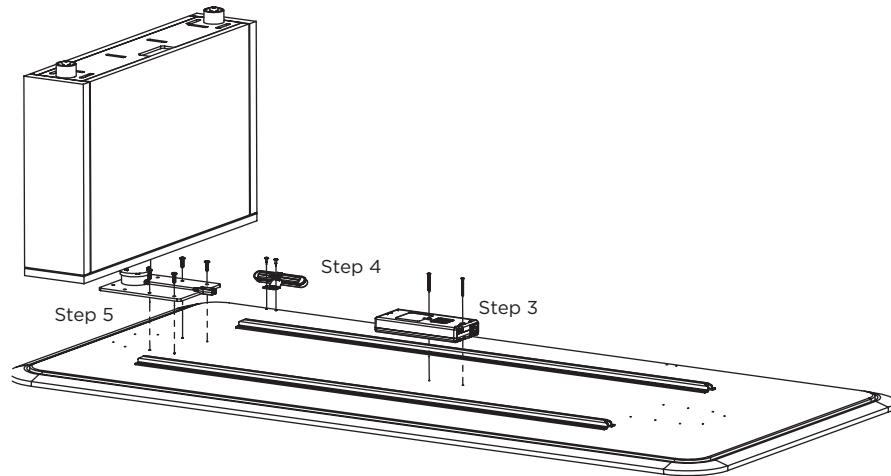

6. Flip over previously assembled top and runoff base and place on wall cabinet mounting plate as shown below. (Will not be fastened until Step 9.)
7. Connect the runoff base and wall cabinet lift columns to the control box using the supplied motor cables. Then connect the control switch to the control box. Next, connect the Mains (power) cable to the control box and plug into a power source.
8. Synchronize the lift columns by pressing the DOWN arrow button on the control switch until they bottom out. Once reset, press the UP arrow button to raise the worksurface approx. 10" to access the lift column mounting plates.
9. Once the worksurface is raised, finish installing the remaining screws from HK-71, aligning the holes in the mounting plates with pre-bored holes in the top.
10. Use remaining screws from HK-83, along with the wire clips and one wraps to clean up wires underneath the top as desired.
11. Use the DOWN arrow button on the control switch to lower the top back to the lowest position and level the runoff base as needed to level the worksurface.

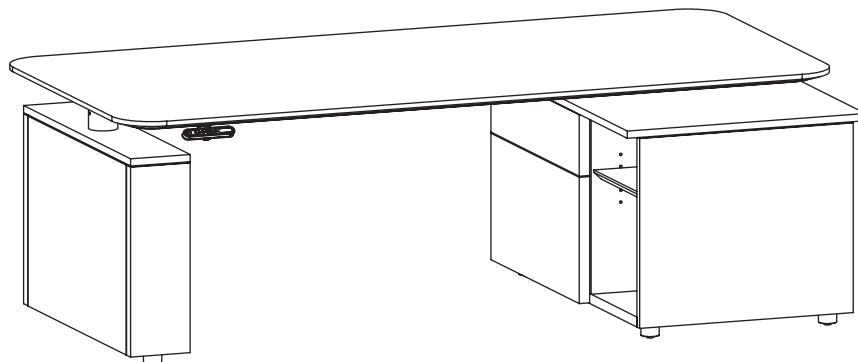

Modular pedestals

Worksurface installation:

1. Cabinets can be built either upright or upside down.
2. Remove drawers and adjustable shelves from pedestals.
3. Lower fold-down backs in open pedestals.
4. Cabinets can be pilot bored and screwed together using #8 x 1 ¼" pan head screws. Note: This will deface the outside of these cabinets).
5. Place worksurface on cabinets with 1.25" overhand to front and back of Side Panel.
6. Attach worksurface by screwing #8 x 1 ¼" pan head screws (HK-15) through pre-drilled holes in case spacers or top panels.

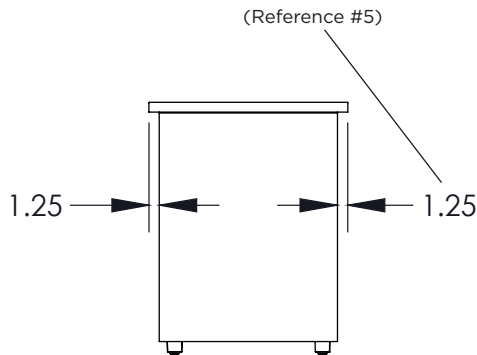

Worksurface height cabinet

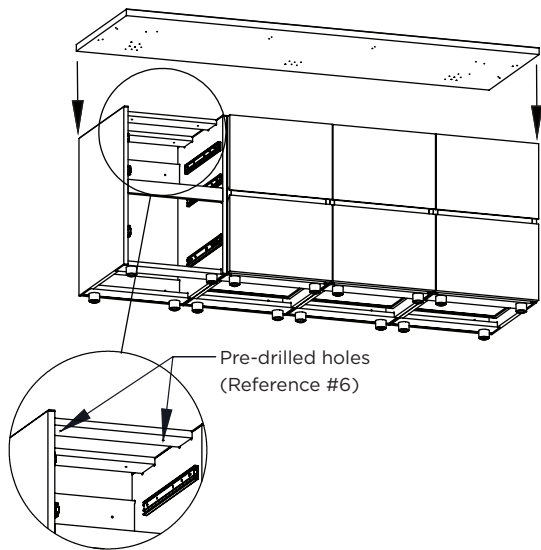

Low height modular cabinet

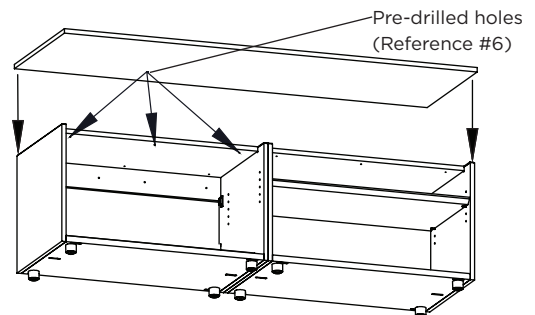

Modular pedestals, continued

Back panel installation:

1. Place back panel against cabinets so vein lined edge is against end panels. (Figure A)
2. Use a pry bar to lift back panel unit it contacts the worksurface and is flush to the bottom of the end panels.
3. When back panel is in place, secure by screwing #8 x 1 1/4" pan head screws (HK-15) through pre-drilled holes in case spacers.

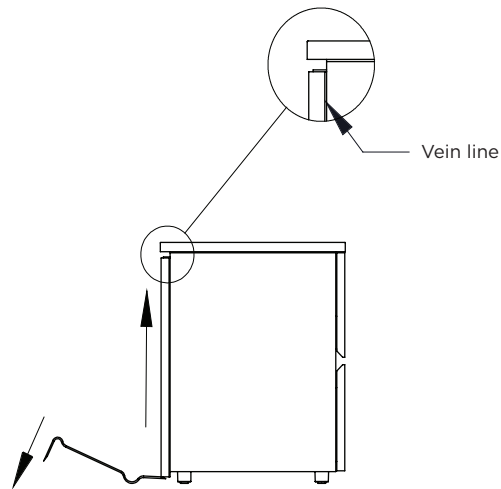

Worksurface height cabinet

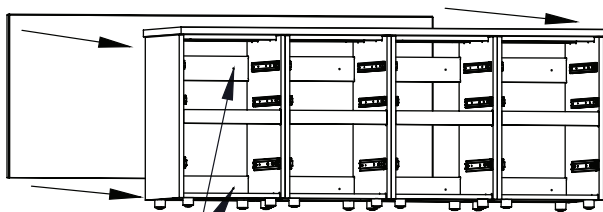

Pre-drilled holes
(Reference #3)

Low height modular cabinet

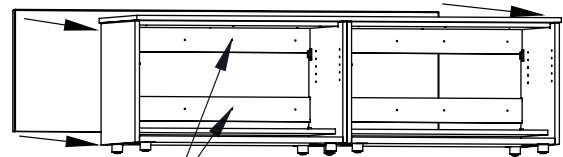

Pre-drilled holes
(Reference #3)

Wallmount storage / tackboard

1. After cabinets are assembled and leveled in desired location, use a carpenter's level to draw a line where the top of the wallmount storage or tackboard will be.
2. The line will be either 38.75" above a worksurface height cabinet or 46" above a low height cabinet
3. Draw a second line 3" lower than the first line for the wall unit or upper tackboard wall bracket.
4. If mounting a tackboard under a wall unit, draw an additional line 17.5" below the first line.
5. Draw last line for lower tackboard wall brackets 35" lower than first line for worksurface height cabinets or at 40" for low height cabinets.
6. Position the wall brackets (Detail B) so the bottom edges are on lines and are also positioned so they will line up with the brackets that are mounted onto the back of the panels. (A small level is included and can be snapped onto the wall bracket, to aid with installation (Bracket B). Mark the hole locations.
7. Drill holes into the wall where marked and fasten the wall brackets. Hardware is provided, but may not be appropriate for your wall type. A professional contractor should determine the best attaching hardware for each specific application.
8. Remove the small level from the wall brackets once they are attached to the wall.
9. Hang tackboards onto the wall brackets first. Then hang wall units.

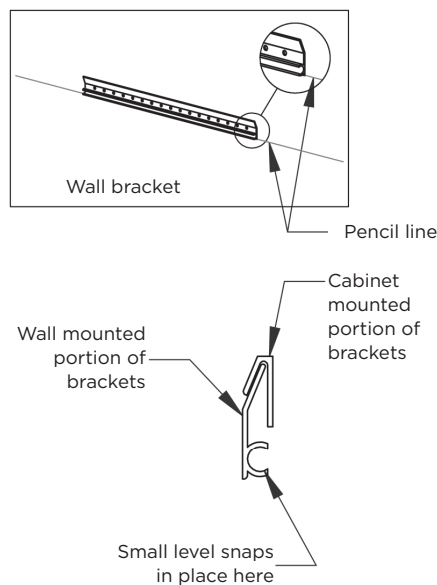
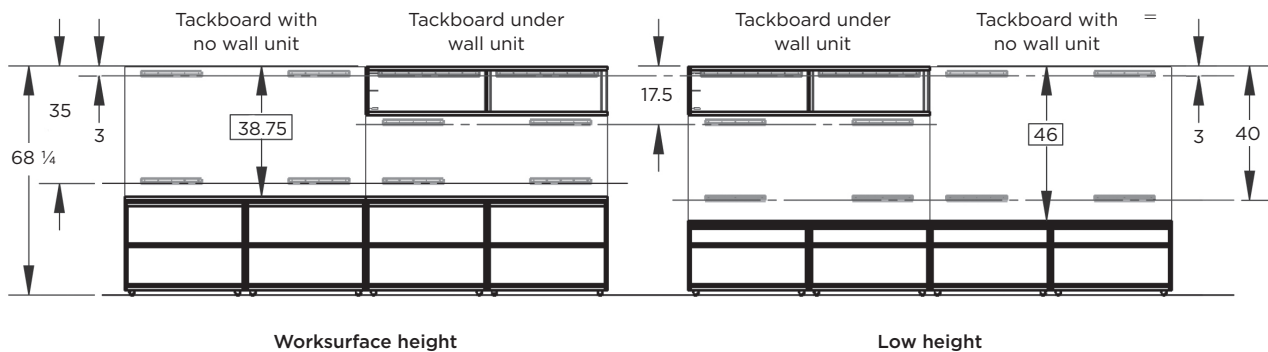

Worksurface storage

1. Peel off one side of backer on two-sided tape.
2. Apply two-sided tape to bottom of cabinet.
3. Peel off second backer.
4. Position cabinet where desired, with back edge flush to the edge of the top, and set in place.

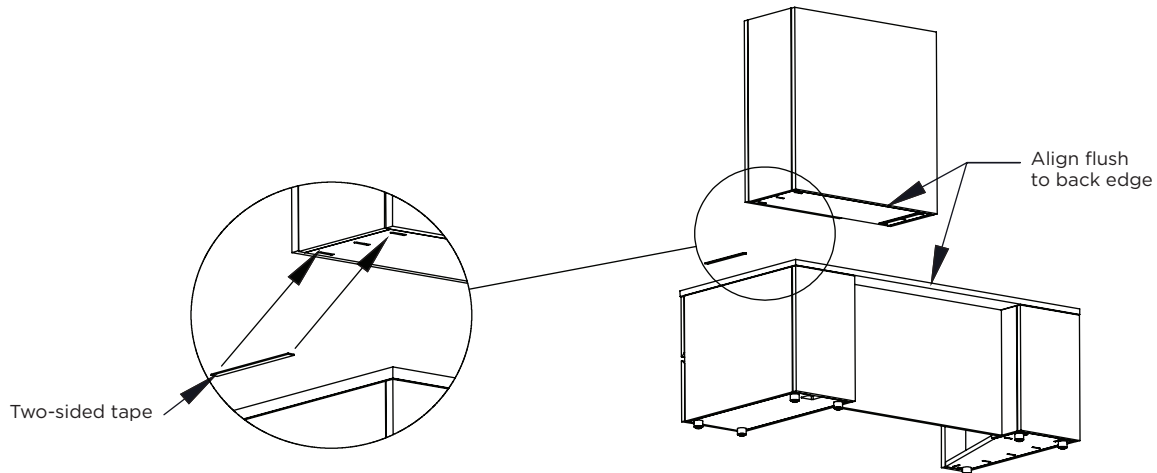

5. Position Stak-EM-Paks (HK-7) so they are parallel and inset from the edge of the back panel by at least $\frac{1}{4}$ ". The rounded edge of the Stak-EM-Pak should also be flush to the bottom edge of the top.
6. Mark hole locations and pre-drill $\frac{1}{8}$ " diameter x $\frac{1}{4}$ " deep pilot holes.
7. Secure Stak-EM-Paks with #8 x $\frac{5}{8}$ " pan head screws. (HK-7)

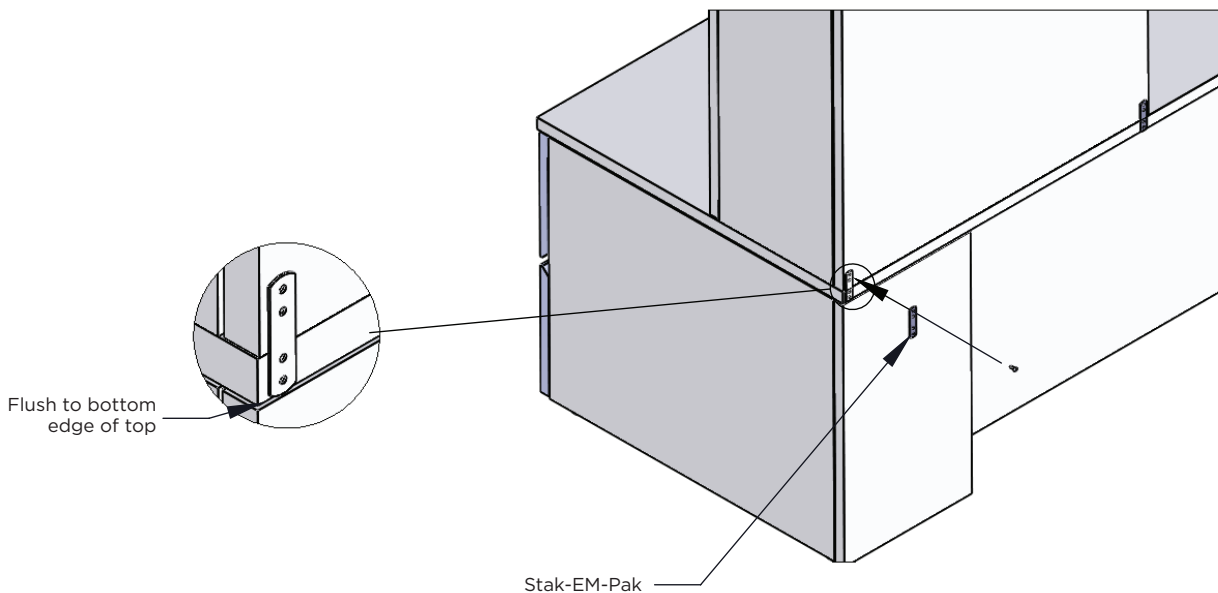

Edge mount privacy panels

1. Aligning the holes in the brackets with the pre-bored holes in the panel attach (3) mounting brackets to the privacy panel using (2) #8 x 1.5" pan head screws in each bracket.

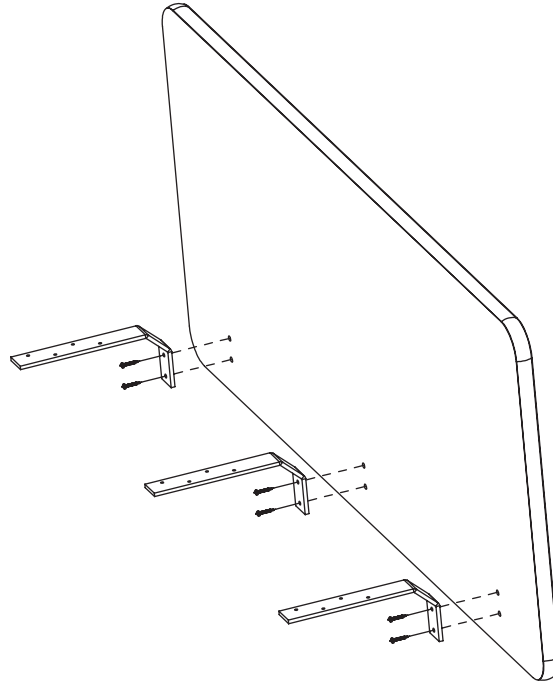

2. Leaving a 1.5" wire management gap between the worksurface edge and the face of the privacy panel, locate the privacy panel centered in the kneespace of the desk with the top of the mounting brackets flush to the underside of the worksurface using (4) #8 x 1" pan head wood screws in each bracket.

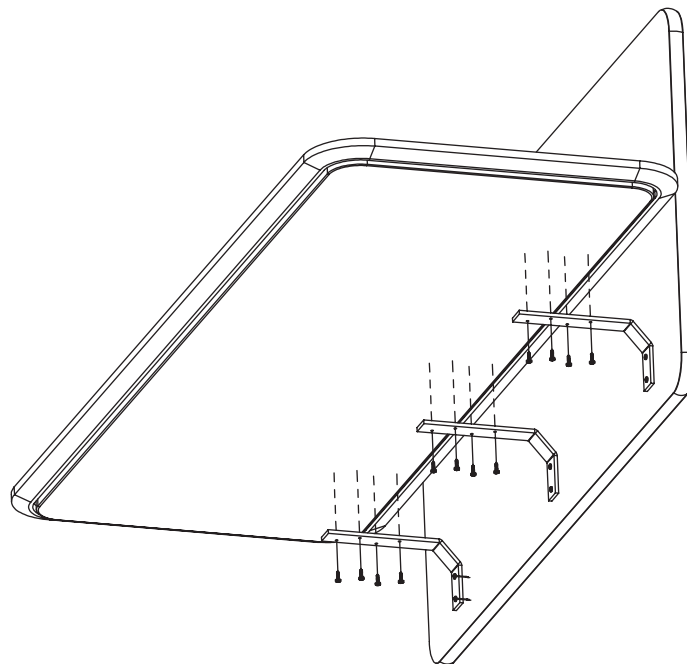

Surface mount privacy screens

Note: If unit was pre-bored at the factory, move to Step 4.

1. Determine "Y" dimension (center of privacy panel) and tape off area to be drilled to protect finished surface.
2. Locate template in desired location using centerlines of template and center punch the 2 locating holes on template.
3. Remove template and verify 30" center to center between locating hole marks and drill 2 holes $\frac{3}{8}$ " diameter to a depth of $\frac{5}{8}$ " at previously marked locations, remove tape after drilling.
4. Install (HK-118) mounting pins into $\frac{3}{8}$ " diameter holes and secure with supplied #10 x 1" screw (2 per pin) long edge of plate parallel to length of privacy screen.
5. Position privacy screen onto mounting pins aligning holes in bottom of privacy screen and slide down to worksurface.

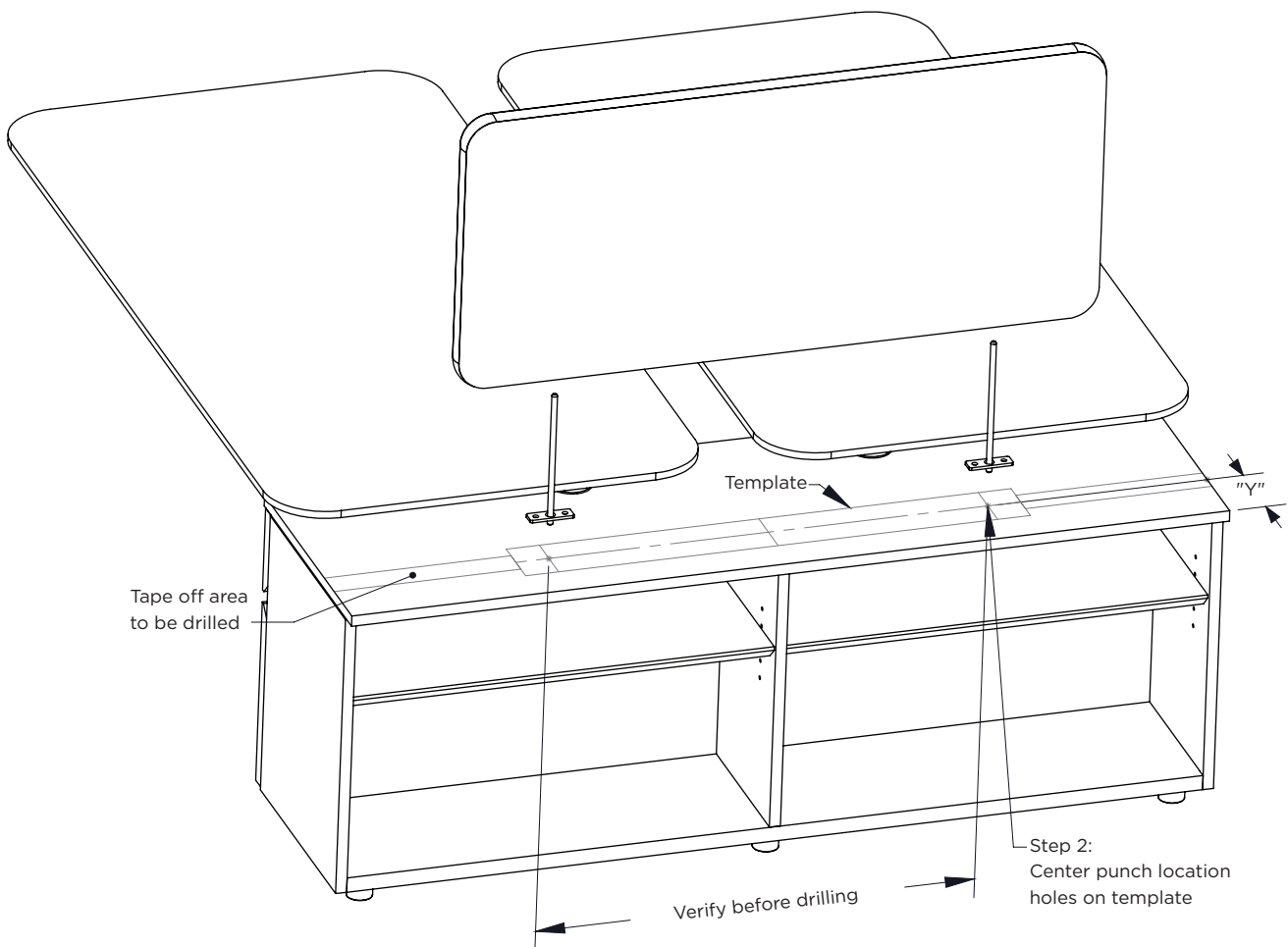

Open plan

1. Unpack and verify all cabinets, cross rails and tops.
2. Determine foot print size.
 - A. Width (X) is determined by adding all height adjustable cabinet depths and knee spaces. (Add 8" for 6"D bases).
 - B. Depth (Y) is determined by adding all widths of add-on storage cabinets in the longest run.
3. Using the foot print size, locate the center of the unit to start assembly.

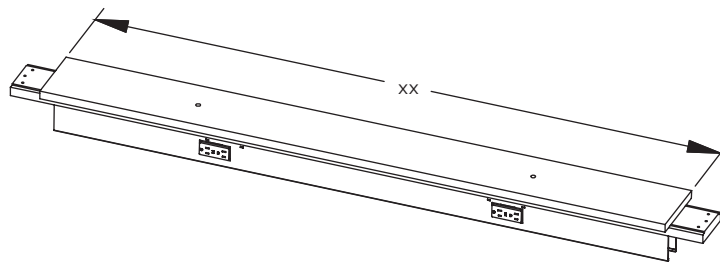

Locate cross rail and measure finished top of assembly to determine knee space size

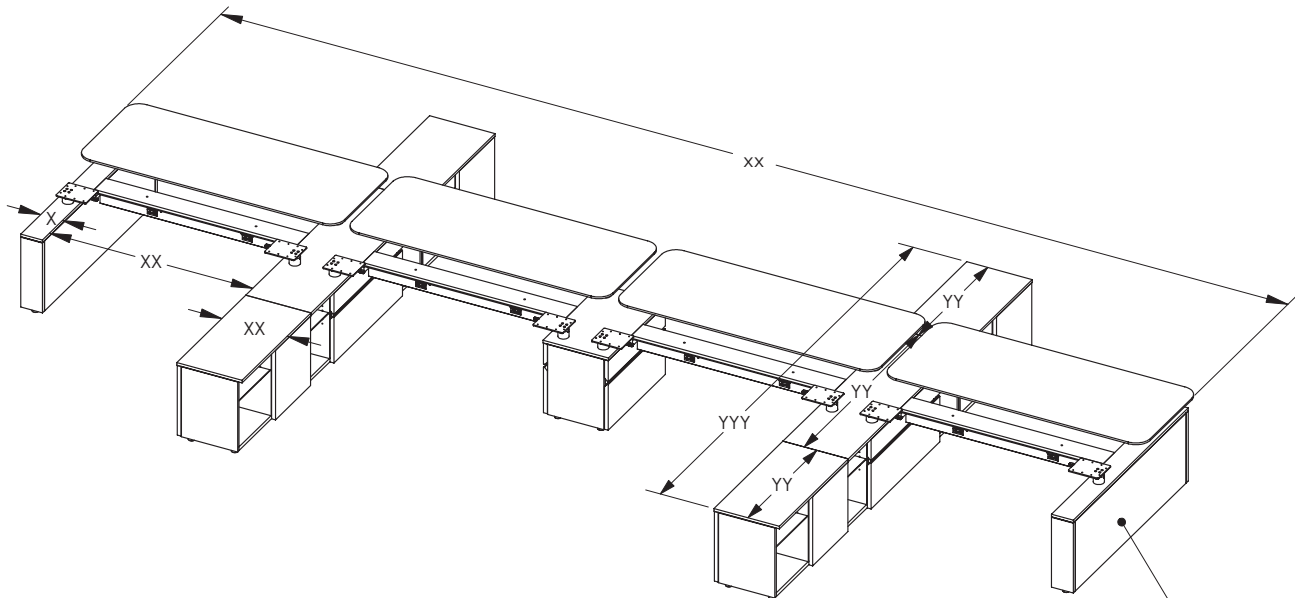

Note: If a 6"D end base is chosen, add 8" when calculating overall footprint width, the worksurface will overhang outside of base 2".

Open plan, continued

4. After determining the center of the unit in the space available, place height adjustable bases to match the configuration of the spec drawing for the set up. Inserting the cross rails into wire management cut outs on the side of the height adjustable bases. Securing them at a later time. (6"D bases will not stand alone until attached to the cross rail.)
5. Rotate the worksurface mounting plates from the shipping position to overhanging the knee space as shown below.
6. Begin leveling 2 of the bases using a level to span the mounting plates front to back and across the knee space to the next base side to side. Up to 1" of adjustment is available by turning the leveler foot out. Once the bases are level the cross rail can be attached. Mark the center of the top of the height adjustable bases and each end of the cross rail top for alignment. Remove the lower panel of the bases (pull towards knee space) for access and attach cross rail using HK-15. Place a square along the edges of the cross rail top and base top to ensure squareness before securing.
7. Repeat until all bases are level and cross rails are installed square.
8. Connect the power jumper from one cross rail to the next through the wire management cut out in the height adjustable bases. Connect the in-feed and have wired into floor core.
9. If applicable- to install privacy panels, reference instruction sheet.

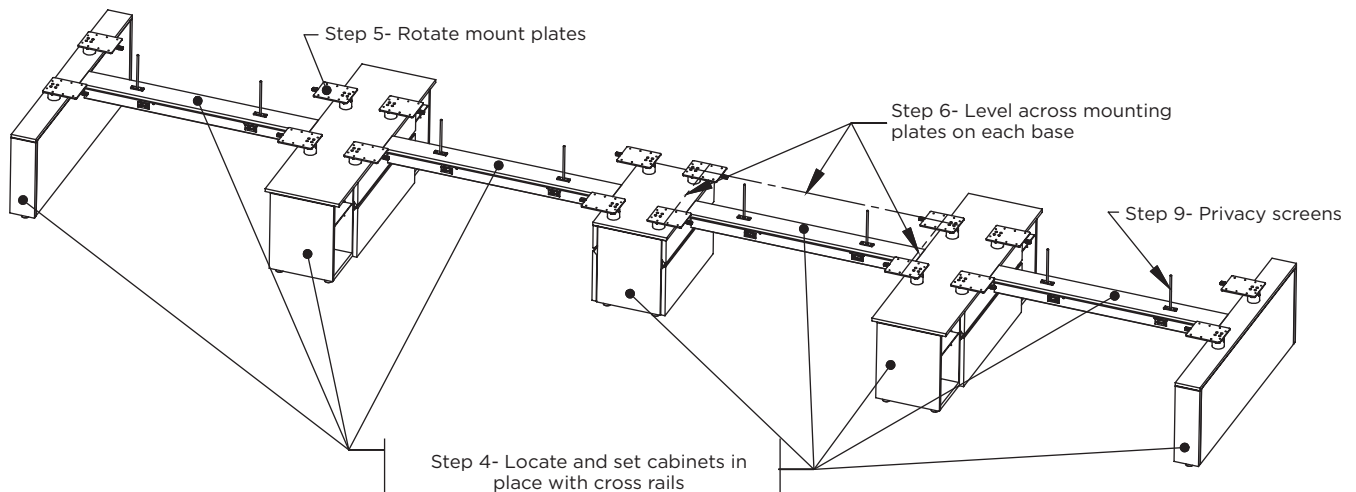

Open plan, continued

10. Locate and place shared storage cabinets. Align and level with previously installed height adjustable bases.
11. Temporarily connect control box to the lift columns with the control cables, connect control switch to the control box and connect the mains (power) cable to the control box and then plug into a power source.
12. Press the down arrow button on the control switch to synchronize the lift columns. Press the up arrow button on the control switch to raise the lift columns, allowing access from the bottom to attach the worksurfaces.
13. Place a worksurface on two lift columns spanning across a knee space. With one person supporting the top and a second person securing the worksurface from underneath using a HK-71 aligning the holes in the mount plates with the pre-bored locating holes in the bottom of the sub top. Repeat for remaining tops.
14. Mount the control box with HK-73 aligning with the 2 locating holes in the bottom of the worksurface and the control switch using HK-83 using the pre-bored locating holes on the left or right side of the user edge of the worksurface.
15. Use the remaining screws from the HK-83 along with the cord clips and one wrap to clean up and secure wires underneath the worksurface as desired.

