

Trace power ring assembly instructions



Important safety instructions

When using an electrical furnishing, basic precautions should always be followed, including the following:

This furnishing is made for commercial use only.

Read all instructions before using this furnishing:

DANGER

To reduce the risk of electrical shock:

1. Always unplug this furnishing from the electrical outlet before cleaning.

WARNING

To reduce the risk of burns, fire, electric shock, or injury to persons:

1. Unplug from outlet before putting on or taking off parts.
2. Close supervision is necessary when this furnishing is used by, or near children, invalids, or disabled persons.
3. Use the furnishing only for its intended use as described in these instructions.
Do not use attachments not recommended by the manufacturer.
4. Never operate this furnishing if it has a damaged cord or plug, if it is not working properly, if it has been dropped or damaged, or dropped in water. Return the furnishing to a service center for examination and repair.
5. Keep the cord away from heated surfaces.
6. Do not use outdoors.
7. Use only SJT 18 AWG cord.
8. Risk of injury. Maximum load 75 pounds.

To reduce the risk of electric shock, this furnishing has a polarized plug (one blade is wider than the other). This plug will fit in a polarized outlet only one way. If the plug does not fit fully in the outlet, reverse the plug. If it still does not fit, contact a qualified electrician to install the proper outlet. Do not change the plug in any way.

Note – servicing is only to be performed by an authorized representative.

Servicing of double-insulated products

In a double-insulated product, two systems of insulation are provided instead of grounding. No grounding means is provided on a double-insulated product, nor is a means for grounding to be added to the product. Servicing a double-insulated product requires extreme care and knowledge of the system, and is to be done only by qualified service personnel. Replacement parts for a double-insulated product must be identical to the parts they replace. A double-insulated product is marked with the words “DOUBLE INSULATION” OR “DOUBLE INSULATED”. The symbol (square within a square) is also able to be marked on the product.

Save these instructions

Installation

1. Arrange rail segments on floor
2. Check for color coded stickers on inside face of rails and match like colored rails end to end.
3. Remove power and USB receptacles from rails but keep receptacles and conduit in relative proximity to original position.

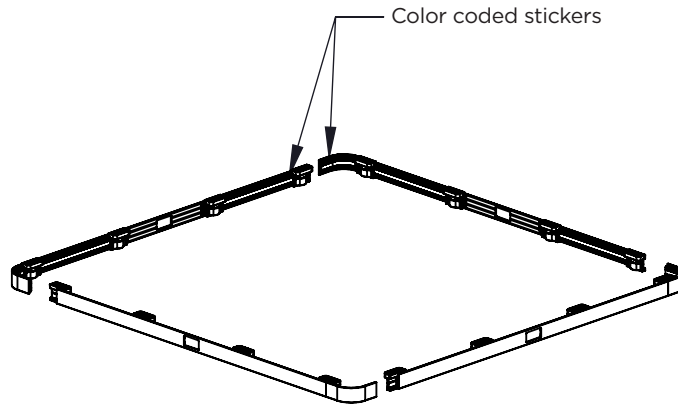

4. Begin attaching rail segments to underside of top by starting in a corner with two rail segments.
5. Using a 5MM allen wrench, loosen plastic clamp on the end of rail segment.
6. Slide rail segments together and retighten plastic clamp (Detail A).
7. Plastic clamp should be centered between two rails.
8. Leave 1/2" overhang on all rails and secure to underside of top using two (2) #10 x 7/8" truss head screws. (Detail B)
9. Continue adding rail segments around entire top.

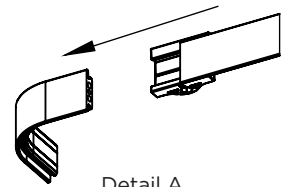
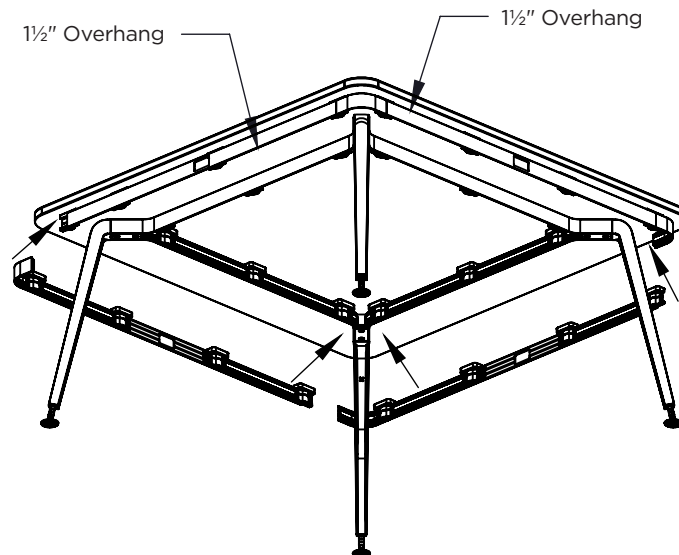

Detail A

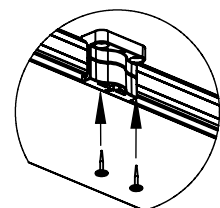

Detail B

Installation (Continued)

10. Position receptacles and jumpers directly under rails where they will be installed
11. Receptacles will alternate between Duplex Receptacles and USB Receptacles.
12. Disconnect jumpers from receptacles.

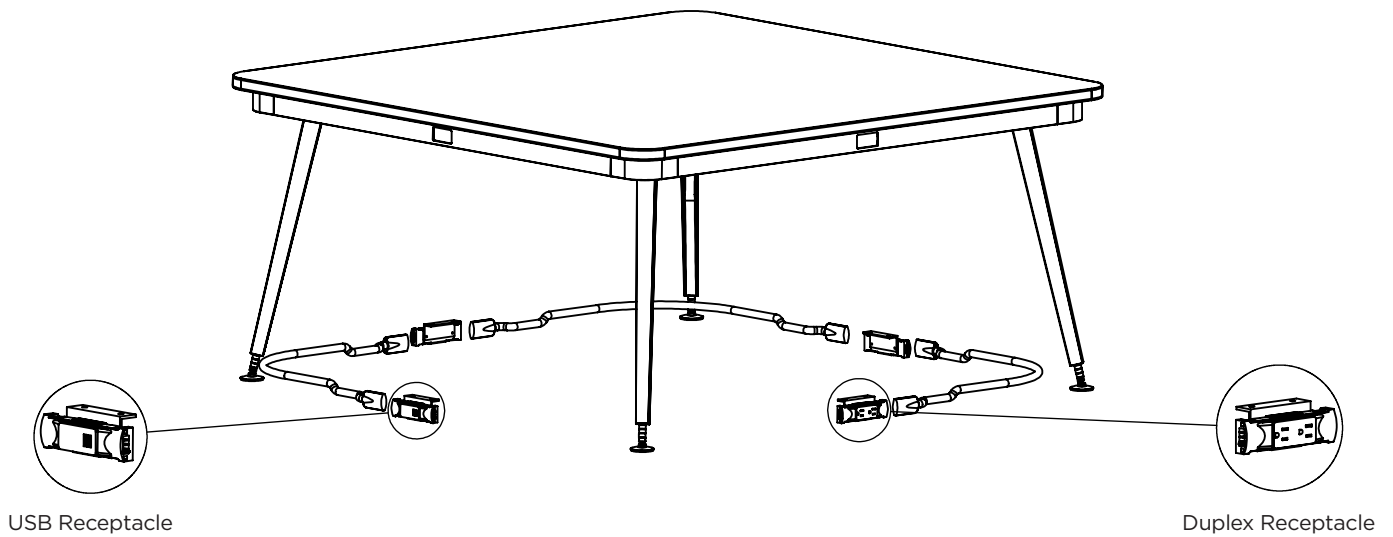

13. Press receptacle assemblies into cut-outs in rails so receptacle faces are flush with rails and L-brackets are positioned against top.
14. Use two (2) #10 x 7/8 truss head screws to secure receptacle assemblies in place.
15. Plug jumper cables back into their duplex receptacles.
16. Use plastic clips to secure jumpers to under side of top.

