

Staks open plan planning guide





Table of contents

Wall panels	
overview	3
panel extension	4-6
panel storage	7
privacy panels	7-8
Worksurfaces	
general planning	9
Supports	
120° typicals	10
clamp plates	11
6-L2S worksurface seam support	11
cantilever overview	12
mini cantilever	13
concealed cantilever	13
worksurface to storage support	14
pedestal to wall brackets	15
full depth pedestal support	15
half round worksurface support	16
riser supports	17
Height adjustable	
height adjustable metal base support	18
height adjustable placement over storage	19
Electrical	
basic electrical terms	20
amp budgeting/UL codes	21
planning for Staks	22
power block/duplex placement	23
jumper planning	24
jumper management	25
infeed planning	26
infeed/data management	27
wiring diagrams	28
2 circuit / 4 wire power	29
3 circuit / 5 wire power	30
4 circuit / 8 wire power	31
Chicago/NYC code/Title 24	32
data	33
Miscellaneous	
filing capabilities	34

Wall panels

Overview

- Panel heights: 33"h, 42"h, 48"h
- **Note:** Additional height can be achieved with use of privacy panels and panel mounted storage. Refer to [Staks building blocks](#) for all height combinations
- LEED certificate max panel height for wall panels: 42"h
- Grain direction on panels will always run vertical
- Panel levelers allow for 1.75" of height adjustability for uneven floor
- CPGLIDE carpet glide allows for 1.5" of height adjustability for uneven floor

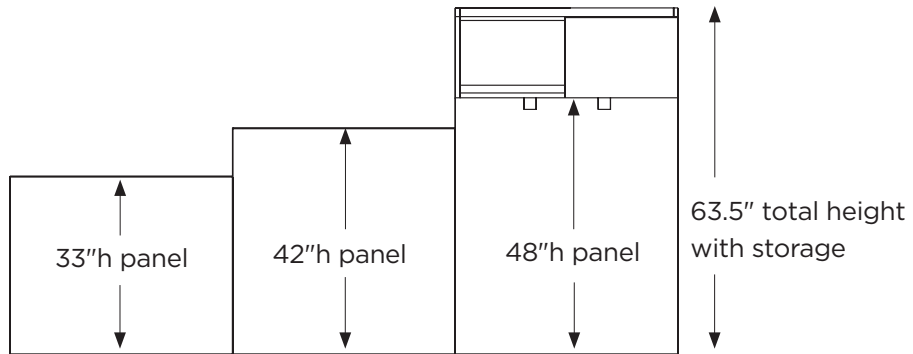

Wall panels

Panel extension for static desks - single panel

- **Note:** This application is for carpet or hard surface flooring
- Using standard glides, a single panel can extend past an approved support connection at any length. **Note:** Max panel width is 59" w (**Figure A**)
- **Note:** The surface to support this panel should be a minimum of 22" d.
- Approved support connections include: pedestal side, pedestal to wall bracket, or end panel (TEP models) (**Figure B**)
- End panel (TEP models) and pedestal side connections requires six connection points to support the panel. Three connection points will be below the worksurface, and three connection points will be closer to the floor. **Note:** Screw connection points will be visible when an end panel support is specified (**Figure B detail**)
- And end panel would be specified if no storage or a mobile pedestal is specified

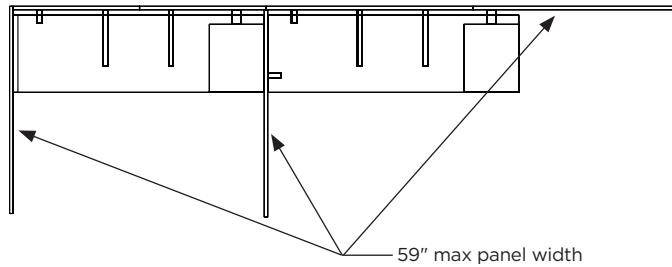

Figure A

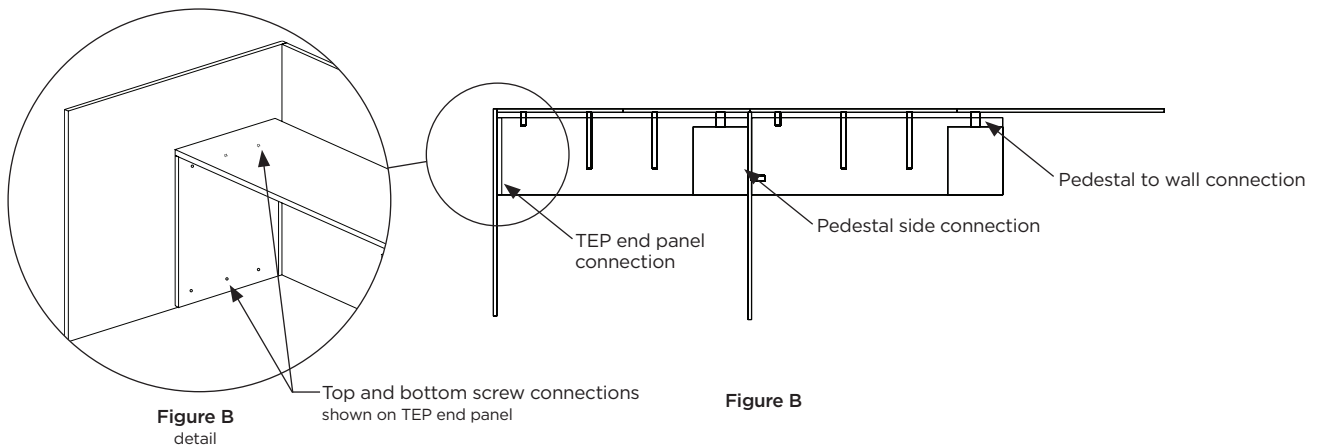
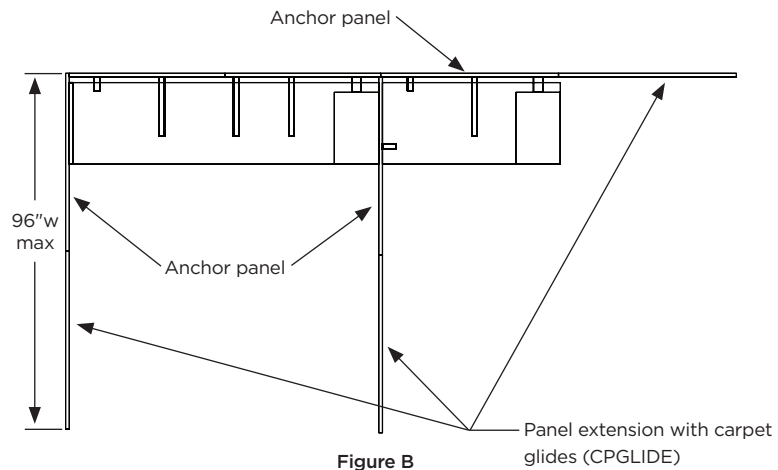
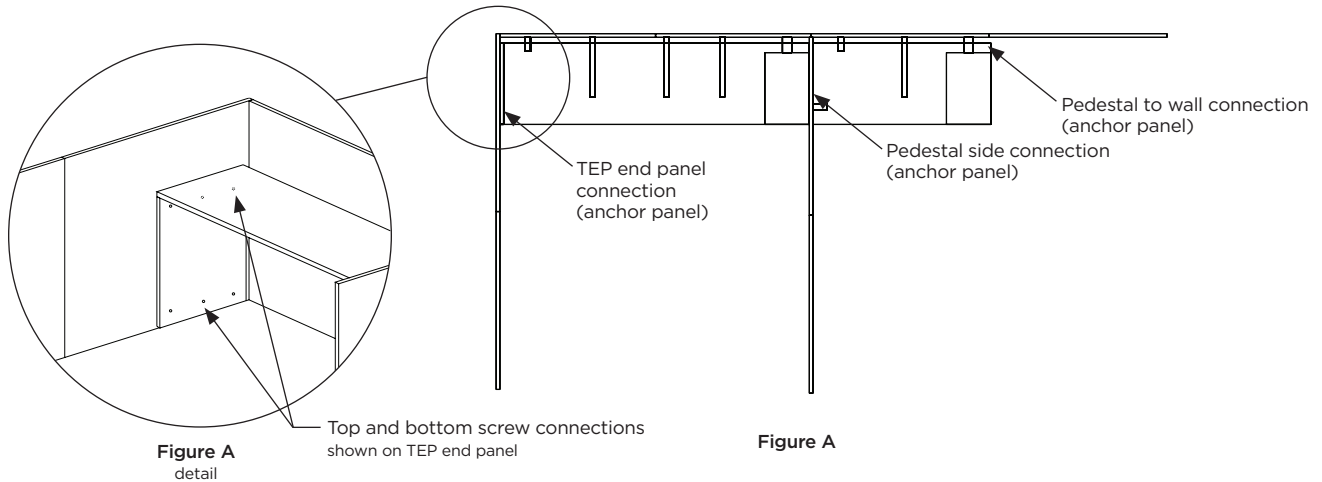

Figure B

Wall panels

Panel extension for static desks - single panel with panel extension

- **Note:** This application is for carpeted floors only. It cannot be used on hard flooring.
- Follow guidelines for supporting a single panel, this will be your anchor panel for this application. Approved connections for the anchor panel include: pedestal side, pedestal to wall bracket, or end panel (TEP models) (**Figure A**).
- **Note:** The surface to support this panel should be a minimum of 22"d.
- End panel (TEP models) and pedestal side connections require six connection points to support the first panel. Three connection points will be below the worksurface, and three connection points will be closer to the floor (**Figure A detail**).
- **Note:** Screw connection points will be visible when an end panel support is specified. An end panel would be specified if no storage or a mobile pedestal is specified.
- Using carpet glides (CPGLIDE), a second panel extension can attach to an anchor panel (**Figure B**). No additional support is required for this panel extension.
- **Note:** The max span of two panels for this application should be no more than 96" of total panel length.
- The carpet glides are specified as a pack of two, and will replace the standard glides that ship with the panel. **Note:** Only the extend panel not connected to a support is required to have the carpet gripper glides. All other panels will utilize standard glides shipped with the panel.



Wall panels

Panel extension for height adjustable desks

Standard glide applications

- When specifying panels perpendicular to a height adjustable desk, a panel span will be limited to 24" past the corner support shelf.
- **Note:** This will utilize the standard glide, and can be used on carpet or hard floor surfaces
- **Note:** If creating a freestanding height adjustable desk with panels as shown below, [6-HAWPB](#) leg to panel brackets are required to support the front panels

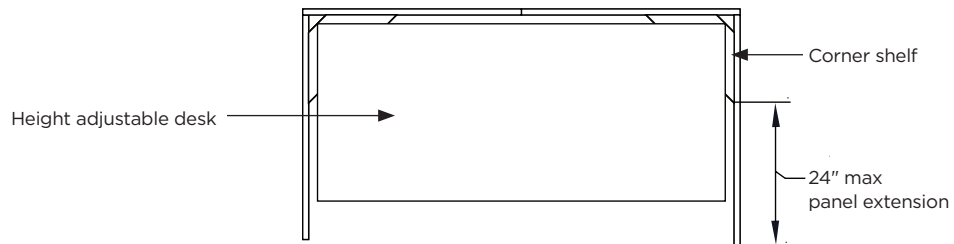

Carpet glide applications

- When CPGLIDE carpet glides are added to this panel extension, the panel width can be specified up to 59" w
- **Note:** This is for carpet applications only
- **Note:** If creating a freestanding height adjustable desk with panels as shown below, [6-HAWPB](#) leg to panel brackets are required to support the front panels

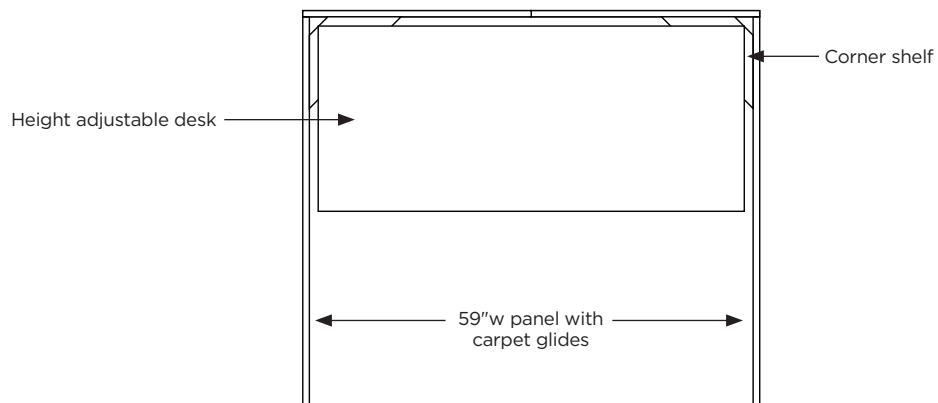

Wall panels

Panel storage

- Panel organizers, shelves, transaction counters are installed centered mounted on the panel using press fit brackets (PFBKT-1)
 - 56" w components and under require two brackets
 - 57"-80" w components require three brackets
 - 81"-102" w components require four brackets
- **Note:** Wall panel support must be used when specifying organizers, shelves, and transaction counters. This support can take the place of a cantilever on 22" d worksurfaces, but not a clamp plate. It should not be placed directly under the seam of adjoining worksurfaces

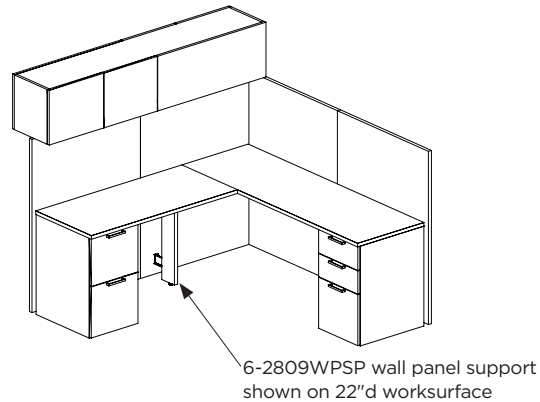

Privacy panels overview

- Refer to the Staks building blocks document for all height combinations
- Available in glass or frosted acrylic
- **Note:** When using acrylic privacy panels, it is recommended to use the privacy panel trim to prevent warping or bowing. Trim can be used for both panel and surface mounted acrylic dividers

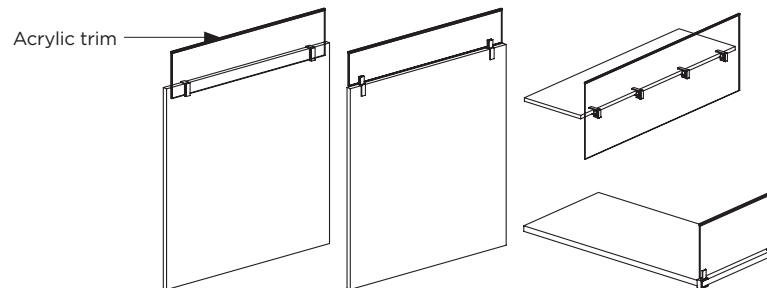

Wall panels

Clamp on privacy panels

- Heights available: 8" h and 11" h
- Maximum width for glass and acrylic clamp mounted privacy panels: 71.5" w
- Can span across multiple panels
- 8" h privacy panel can only be used with PVPBKT-2 panel bracket
 - Adds 8.5" to overall panel height
- 11" h privacy panel can be used with PVPBKT-1 panel bracket and PVPBKT-2 panel bracket
 - PVPBKT-1 add 8.5" to overall panel height
 - PVPBKT-2 add 11.5" to overall panel height
- Privacy panel bracket quantity:
 - 42" w panel & under - 2 brackets
 - 43"-66" w panel - 3 brackets
 - 67"-72" w panel - 4 brackets

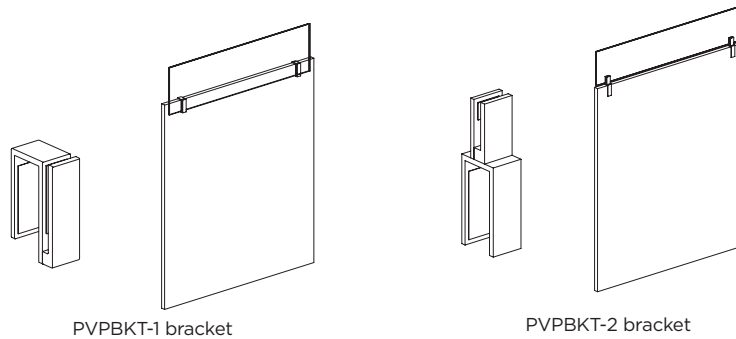

Routed privacy panels

- Heights available: 10" h and 13" h
- 1.5" of the privacy panel will recess into the panel route
- Adds 8.5" to panel height when 10" h privacy panel is specified
- Adds 11.5" to panel height when 13" h privacy panel is specified
- Factory machined route, cannot be added on post install
- For square corner panels the privacy panel will span centered on a panel, leaving 1/2" at each end (**Figure A**)
- For round corner panels the privacy panel will span centered on a panel, leaving 4 1/2" at each end (**Figure B**)
- **Note:** Routed in glass cannot be specified as clear due to unfinished panel route being visible



Worksurfaces

General planning

- When used with wall panels, worksurfaces are spaced 1 ½" away from the wall panel for wire management unless otherwise specified. If flush mounting, a grommet will be needed for wire management
- Maximum unsupported work surface span: 22" w
- Worksurfaces can be supported by cantilevers, end panel, support legs, or pedestals, or other vertical supports

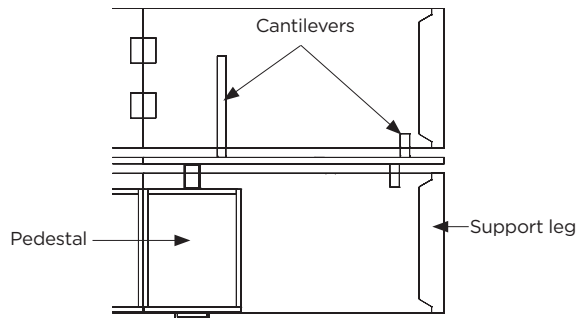

16" d rectangular worksurfaces

- 16" d surfaces can be used in low or desk height applications and must be used with storage for support
- Cannot be used with pedestals less than 24" w
- Pedestals that can be used:
 - Desk height worksurface:
 - Lateral, box/box/file, tray/box/file, open/box/file, open with shelf
 - Low height worksurface:
 - Box/file, tray/file, open/file, open with shelf

22" d rectangular worksurfaces

- 22" d surfaces can be used in low or desk height applications
- Desk height surfaces can be supported with legs, end panels or storage
- Low height surfaces must be supported by pedestals

30/36" d rectangular worksurfaces and non rectangular worksurfaces

- Can be used in desk height applications only
- Surfaces can be supported with legs, end panels or storage

Supports

Open plan - 120° typicals

- When creating a 120° layout, panels will not connect in the center. Instead, brackets and cantilevers will attach panels to the surfaces for stability
- **Note:** Order TOOL-3 to properly space the panels during installation
- Panel mounted overhangs and privacy panels can still be used. Reference [panel storage section](#) for support rules
- The center of the surface will be supported by OSWBKT22 cantilevers (**Figure A**)
- The WSBKTC mini cantilever should be used to secure the worksurface and panels together. These brackets should be placed 3" from the ends of the panel to the edge of the bracket. Keep the brackets mounted on the same side of the panel, two are required for each panel/worksurface
- The ends of a 120° station can be supported with support bases or by mounting flush against a panel by using the SCWBKT-1 bracket as mentioned above

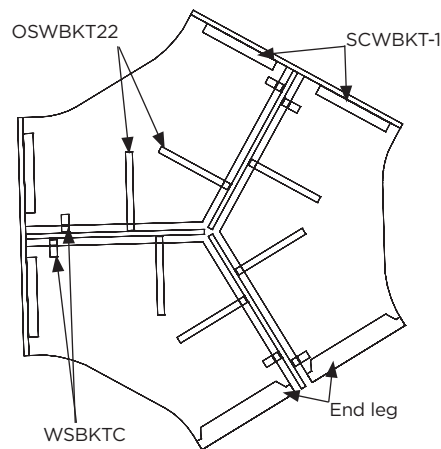

Figure A

Supports

Clamp plates

- Two adjoining worksurfaces will be connected by CP-1 clamp plates
 - Two clamp plates for 22" connections (**Figure A**)
 - Three clamp plates for 30" and 36" connections (**Figure B**)
- Quarter round surfaces should be supported with CP-1 clamp plates on both seams (**Figure C**)

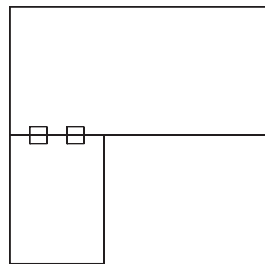

Figure A

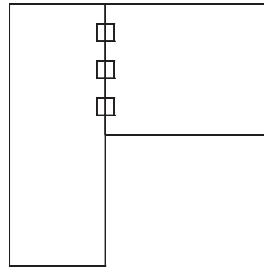

Figure B

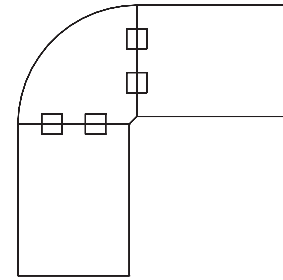
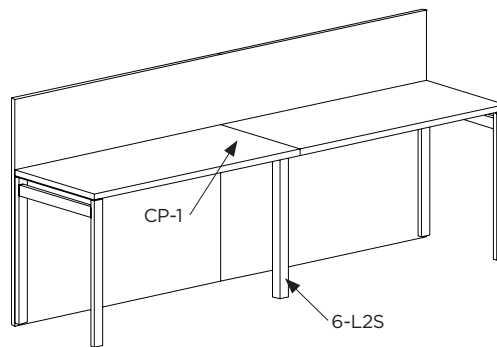

Figure C

6-L2S legs

- CP-1 clamp plates can be replaced with 6-L2S legs. This provides extra support at the seam and is most often used in longer spans where there are no pedestal supports being used. Two 6-L2S legs can replace two CP-1 brackets, or you can use one back CP-1 plate and one front 6-L2S leg at the worksurface seam.
- **Note:** 6-L2S leg required at front seam of 30" and 36" d worksurfaces when pedestals are not used



Supports

Cantilevers overview

- **Note:** Max spacing between cantilevers is 22" unless the panel is secured by other vertical supports (**Figure A**)
- Cantilever brackets on the seam could interfere with the clean-seam connectors and should be avoided at all times. Move the brackets 3" to the left or right of a seam in order to avoid mounting screws from hitting the clean seam connector screws (**Figure B**)
- Brackets should not be mounted back-to-back, but instead be offset from one another by 2". This is to avoid weakening the core material and also to prevent the mounting screws from hitting each other (**Figure C**)

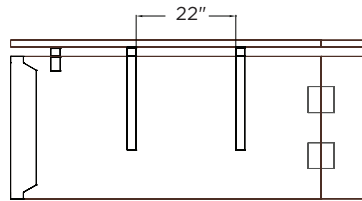

Figure A

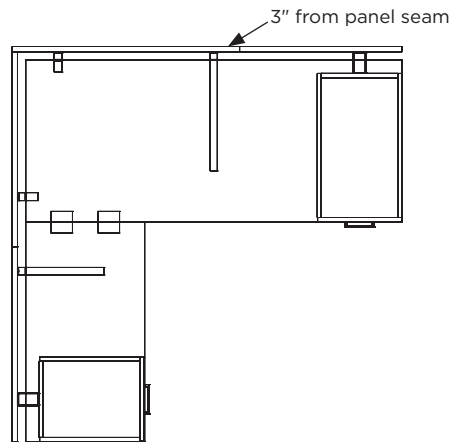

Figure B

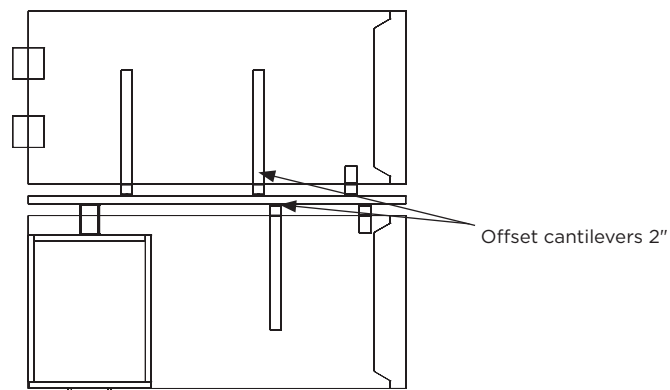
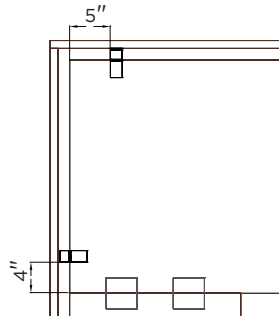

Figure C

Supports

Mini cantilevers

- Worksurfaces that join to panels on the short end (22", 30" and 36" ends) shall have two mini cantilevers (WSBKTC) to support the worksurface corner. One mini cantilever is mounted 5" from the front edge of the surface to the front edge of the bracket. The second mini cantilever is mounted 4" in from the end of the surface to the edge of the bracket



Concealed cantilever

- Concealed cantilevers are to be used at the end of a worksurface and panel connection to clean up the aesthetics of the unit. i.e. at the end of a work surface supported by an H-Leg. This should not be used to replace all other standard OWSBKT cantilever brackets

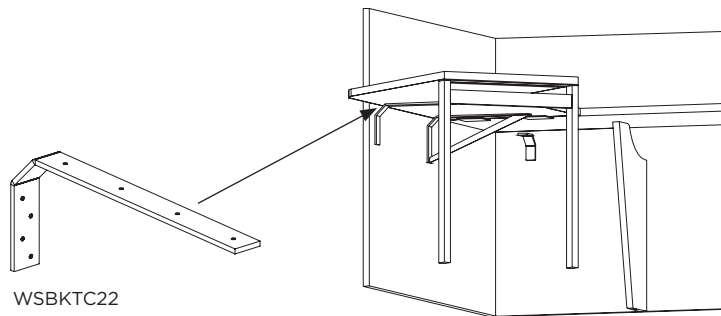

Supports

Worksurface to storage connection

- Using a worksurface to storage bracket (SCWBKT) allows you to attach a worksurface to a panel (**Figure A**), tower (**Figure B**), or pedestal (**Figure C**)
 - Use one SCWBKT-2 on 16" d worksurfaces
 - Use one SCWBKT-1 on 22" d worksurface
 - Use two SCWBKT-2 on 30" and 36" d worksurfaces
- **Note:** This does deface the side of the storage unit. If this is not desired, then a base, end panel or pedestal should be used to support the surface depth

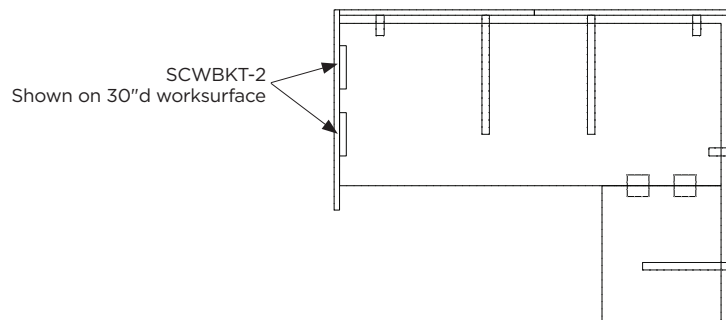

Figure A

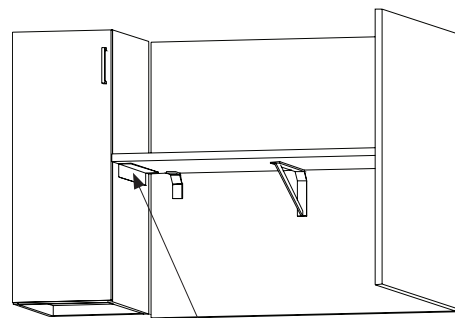

Figure B

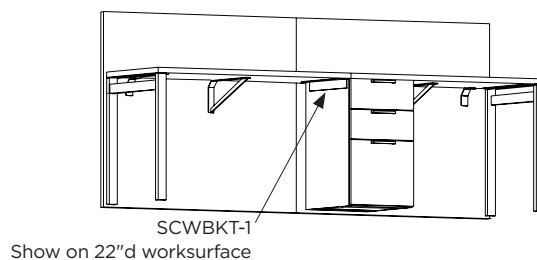

Figure C

Supports

Pedestal to wall brackets

- To be used with pedestals on worksurfaces that have a 1.5" wire management gap (**Figure A**)
- When connecting a pedestal to a panel, one of the following brackets is required:
 - PEDBKT-1 Z shaped: Standard pedestal bracket
 - PEDBKT-2 L shaped: Used with open pedestals specified with hinged back panel

These brackets are used with a:

- 19"d pedestal with 22"d worksurface
- 27"d pedestal with 30"d worksurface
- 33"d pedestal with 36"d worksurface
- Brackets come as a set of 2, one bracket to be installed on top rail, one bracket to be installed on bottom rail
- Use one set for 15.625"w pedestals and two sets for 24"-36"w peds (**Figure B**)

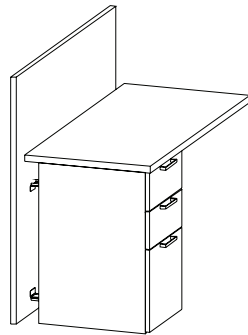
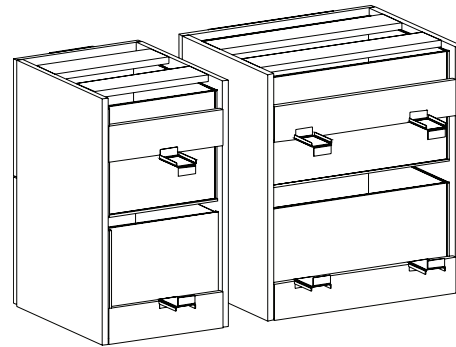

Figure A



15.625"w pedestal

24"-36"w pedestals

Figure B

Full depth pedestal applications

- Pedestals placed at the end of a worksurface with panels should be full depth and have a finished back for a clean aesthetic. A mini cantilever should be placed along the panel on the inside of the pedestal to support the panel (**Figure A**)
- When specifying a 22"d pedestal flush to the wall panel, the wall panel should be attached to the pedestals using screws through the top and the bottom back support rails (**Figure B**)

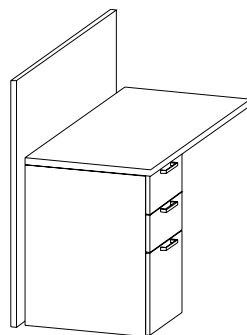

22"d pedestal with wire management gap

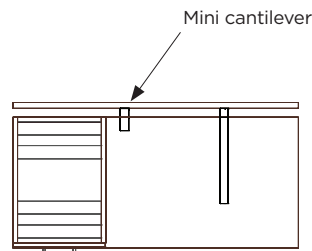
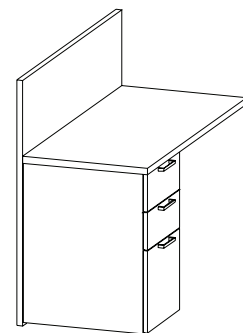

Figure A



22"d pedestal flush to wall panel

Figure B

Supports

Half round worksurface with cantilevers

- When mounting a half round worksurface at the end of a run, the surface will require two 6-L2S legs as well as supporting the seams with CP-1 clamp plates and cantilevers
- The leg should be mounted 10" from the seam to the center of the legs, and 11" from the ends to the center of the leg

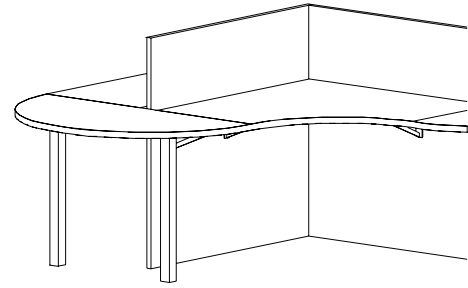
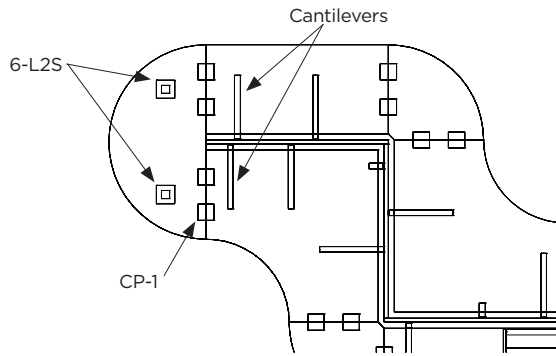

Half round worksurface with pedestals

- If the adjacent surfaces are supported by storage, only a single leg is required. This would be located 11" in from the edge of the surface to the center of the leg, and centered on the radius (24" from both sides) to the center of the leg. Use SCWBKT-1 to connect surface to pedestal

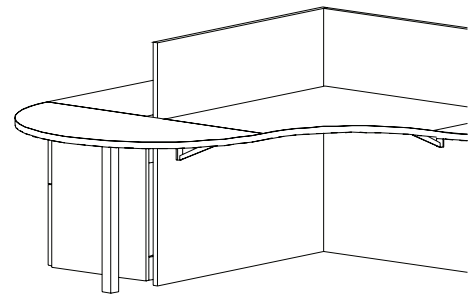
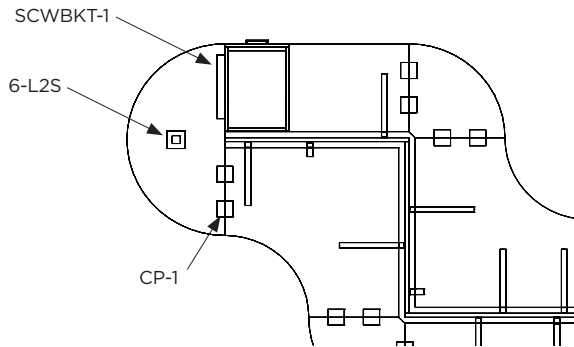

Supports

Riser support general

- Riser supports are used to support worksurface to low height, and low to bench height applications
- **Note:** Riser support is also used to go from low height to bench height as well. This option is only available with 22" deep surfaces

T riser support

- These supports are placed with the top of the "T" running parallel to the end (depth) of the top they are supporting, with the leg of the "T" extending toward the end of the surface (**Figure A**)
 - 6-RSP-10/9.5 - Used under a 16" deep worksurface
 - 6-RSP-10/9.5 - Used under a 22" deep worksurface
 - 6-RSP-26/9.5 - Used under a 30" deep worksurface
 - 6-RSP-32/9.5 - Used under a 36" deep worksurface

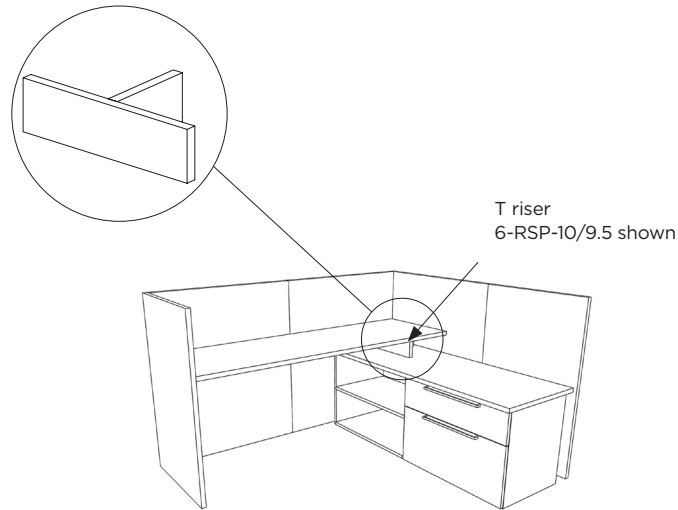

Drawer riser support

- Finger pull handed left or right (**Figure B**)
 - 6-(L/R)RSP-1815 - Used under a 22" deep worksurface
 - 6-(L/R)RSP-2615 - Used under a 30" deep worksurface
 - 6-(L/R)RSP-3215 - Used under a 36" deep worksurface

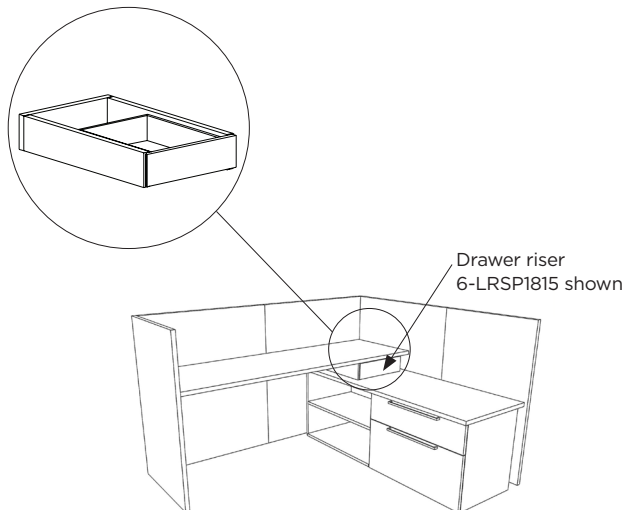

Height adjustable

Supporting height adjustable metal bases in open plan

- A 6-HAWPB height adjustable leg panel wall bracket will be used to support panels spanning in front of a worksurface using height adjustable metal legs
- Bracket attaches to metal legs and then screws directly into wall panel interior
- When using a corner shelf to support panels around a height adjustable desk, the corner shelf should be mounted at 17" AFF. If using the 6-HAWPB support brackets, they would install directly below the shelf.
- Max 24" panel extension past worksurface to maintain proper panel support (**Figure A**)
- Use with bases HA24KCRE; HA30KCRE; HA24KCSE; HA30KCSE; HA24KFRE; HA30KFRE; HA24KFSE; HA30KFSE; 6-5836HALWT; 6-7036HALWT; 6-5836HARWT; 6-7036HARWT
- Metal height adjustable bases to be used with surfaces 48"w to 72"w only. Use 24"d bases for 22"d surfaces. and 30"d for 30"d surfaces
- When using panels around a height adjustable desk, a 6-2108SHLF corner shelf must be used to support the panels at a 2 way connection (**Figure B-C**)
- Panels in front of the height adjustable desk should span no more than two across, allowing a 6-HAWPB bracket to attach to each panel
- When leg brackets are used, worksurface maintains 1.5" wire management gap from panel

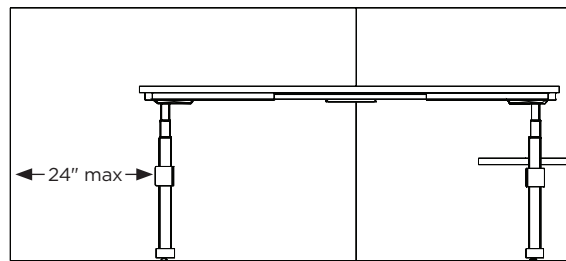

Figure A

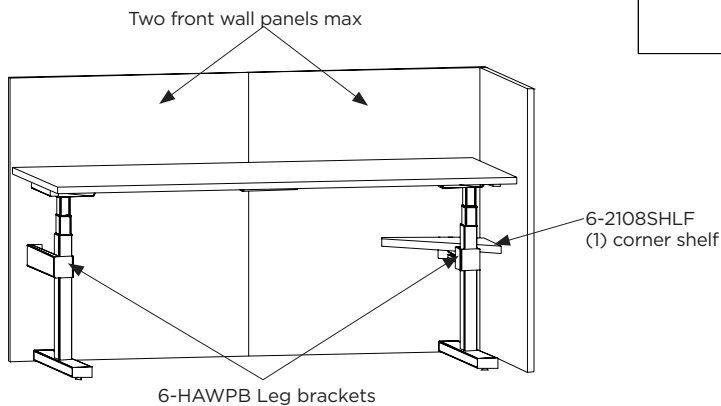

Figure B
(no end wing panel)

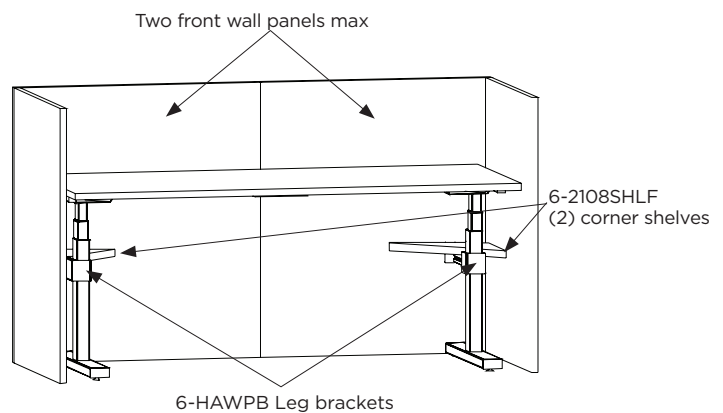
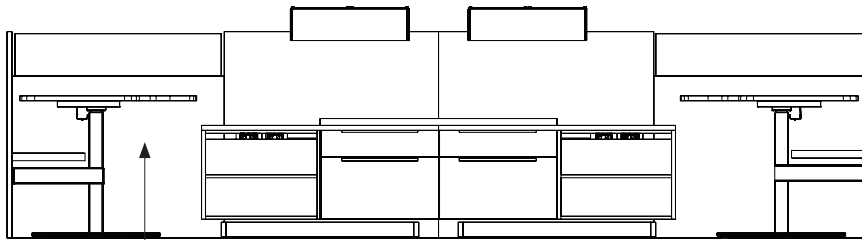

Figure C
(with end wing panel)

Height adjustable

Height adjustable table placement over storage

- Staks height adjustable tables have a minimum clearance height needed should the table need to be reset. Because of this, it is important to understand placement guidelines when using height adjustable desks over storage
- In an open plan setting, where a desk could not be moved to reset the desk, the HA adjustable desk cannot be placed over low storage. Instead, it must be placed in front of the storage, so the desk is not overlapping the storage. (Figure A)
- **Note:** A height adjustable desk can be placed over bench height storage. (Figure B)
- In a private office application, where there would be space to move the desk away from the storage, a height adjustable desk **can** be placed over low height storage. A mobile pedestal can also sit under the desk. The mobile pedestal would need to be moved away from the under the desk before resetting (Figure C)



Height adjustable table in front of low height storage

Figure A

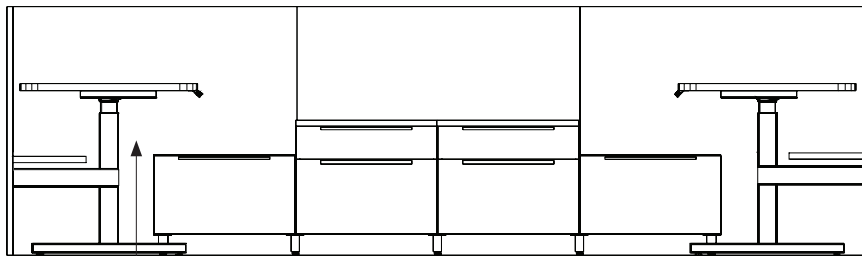

Height adjustable table over bench height storage

Figure B

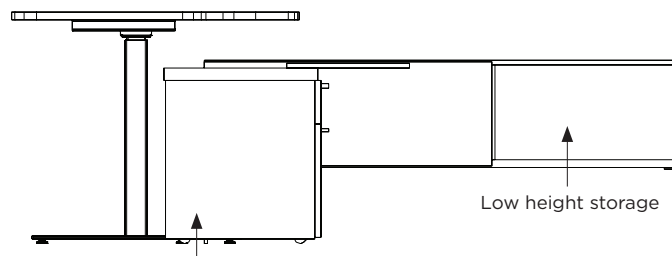

Mobile pedestal

Figure C

Electrical

Basic terms used when dealing with and selling electrical

Amps:

Unit of electrical measurement commonly used to rate power requirements of the equipment. For example, your laptop requires 3.36 Amps. Typical commercial electrical wall outlets are wired for 20 Amp service. Older buildings may have the older standard/ residential 15 Amp service.

Circuit:

Individual circuits feed off the main service to the building, carrying electrical power through the circuits to each room. A commercial circuit is typically rated at 15 to 20 Amps each, depending on the application or need.

Hard wire:

Electrical connection of power feed supplying furniture and equipment to building power source. Requires a certified electrician to install a hardwire connection. Usually hardwire connections are used for multiple circuit access from the power source.

Wire manager:

Wire manager is a generic term used to describe organization of electrical, voice and data cables in furniture.

Power block:

Duplex unit which holds the modular circuit receptacles.

Underwriters laboratory - UL:

The mother of all electrical standards-see special section on Byrne UL 183, Dekko UL 962 for specifics.

Jumper:

Modular link connecting power blocks/duplexes between furniture. Sometimes referred to as daisy chaining.

Hot, neutral and ground:

Terms used to describe the different types of wires used in electrical schematics.

- **Hot:** Each circuit requires a hot wire to carry the electrical power. Hot circuits can be shared or isolated.
- **Neutrals:** The neutral is also required to complete the circuit. It is the return portion of the circuit and carries the electrical power back to the ground in effect completing the circuit.
- **Grounds:** This wire is a safety net in the event a hot or neutral fails. It creates a safe path back to the ground versus sending the energy through the utility (e.g. computer).

Modular connection:

Another term used in placing of jumpers.

Power strip:

Power plug rated at 15 amps. Allow user to plug several pieces of equipment into one power tap. (Note it is not kosher by NEC standards to daisy chain power strips.)

Category 3:

Commonly used in phone equipment. Lowest rating in terms of speed of transmission of communication and therefore is not used in high-speed modem communication. Typically CAT-3 is a modular connection system.

Category 5:

High-speed communication, usually hard wired to allow maximum communication speed. CAT 5's has a rating of 100 megabytes of information transfer per second.



Electrical

Amp budgeting

The standard equipment found in workstations or cubicle in Corporate America consist of a Computer, Laptop, CPU Monitor, Clock Radio, Cell phone, Battery Charger, IPod, IPad, task light, calculator, and lamp. Below is a list of common items or equipment used in the modern day open plan or private office/conference rooms. These items are shown with the amount of AMPS required.

Laptop Computer/CPU (depends on size): 2-4 Amps

Fax: 1 Amp

Monitor: 2-2.5 Amps

Focus Machine: 3-5 Amps

Printer-DeskJet: 4 Amps

Overhead Projector: 1.5-3 Amps

Printer-LaserJet: 6.5 Amps

UL underwriters laboratory codes

There are three main standards that UL has established and apply to power distribution for the office: (Byrne) UL 183 and (Dekko) UL 962. UL 183: UL 183 standards were developed for modular components used on equipment and in our case tables. UL 183 category can be hardwired, single or multi circuit, single or three phase designs. The standard requires that the electrical system comply with UL standards, but it has no bearing on the furniture. Thus, while the electrical system is considered in compliance, it is up to the furniture manufacture to secure the electric to its product in a safe manner

Electrical

Planning for Staks

This planning section will help you understand how to help your clients with the correct power requirements. In most cases it comes down to asking these simple questions and then making the right recommendations.

1. What will each user be using in the office or open plan?
2. Are we dealing with new construction or existing building specs?
3. Where is the power in the room? Is it flexible-under floor access?
4. Will we need surface power access?
5. How will data be handled? Surface mounted or underneath the surface?
6. Are there any particular local codes or constraints to deal with, such as in NY or Chicago.
7. Is a dedicated circuit required?

The typical project will include a spec from an architect or designers drawing. These drawings will have several rectangles positioned in a creative configuration. Such creative expression often does not lend itself well to reality. That is where you come into the picture.

1. Sell standard product if you can. Sometimes customizing product or changing electric circuits will cause the table not to meet UL codes or BIFMA Standards. Understand the UL Codes we work with in.
2. Over Power the work surface: ask the questions from above. Count the number of computers in each open plan and multiply by the Amps required for each computer. This will tell you how much power the row will require. The NEC has certain rules facilities must abide by. Computers in use for more than 3 hours must down load the capacity of the power supply by 20%. Therefore an eighty Amp hardwire power feed would only be rated at Sixty four amps.

OFS recommends 5 Amps of power per workstation

- 3 workstations per circuit is the general rule
- 6 workstations per 4-wire infeed (based on 5 Amps per workstation)
- 9 workstations per 5-wire infeed (based on 5 Amps per workstation)
- 12 workstations per 8-wire infeed (based on 5 Amps per workstation)

Electrical

Power block/duplex placement

- Power duplexes mount to the underside of the worksurface using a power box, and a power box bracket.
- **Note:** Place duplexes and power blocks in consistent location for each user to maintain consistent jumper lengths.

Static worksurface power placement

- Recommended location would be along the spine wall, where the two surface seams connect. duplex can be placed on either the main or return worksurface. This location is typically most accessible to the user.
- If not placing at surface edge depth, as shown in below images, additional jumper length may be needed.



Static worksurfaces
power shown on main worksurface



Static worksurfaces
power shown on return worksurface

Height adjustable worksurface power placement

- Recommended location would be on return surface, close to height adjustable table seam.
- **Note:** Do not install power boxes on height adjustable worksurfaces. Raising the worksurface will over extend the jumpers and cause damage to power items.



Electrical

Jumper planning

- To maintain consistent jumper lengths, place power blocks in same location for all users.
- When using a jumper to connect back to back power blocks divided by a spine wall, connecting jumper should be a minimum of 18" w.

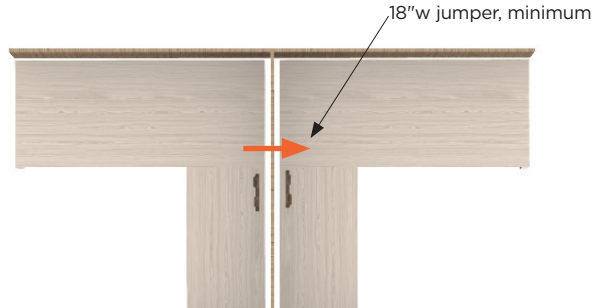

Desk to low height jumper lengths

- When powering duplexes between desk to low height applications, a minimum of 6" must be added to the jumper length for each change of height.

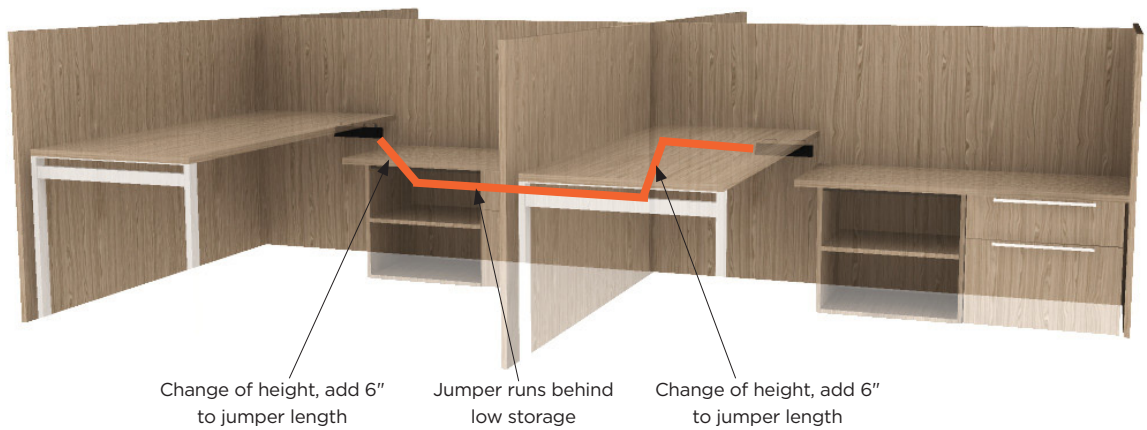

Electrical

Jumper and wire management

- **Note:** Jumpers will run through panel walls by adding field cut grommet holes. GSCGB-1 grommet cover available
- Jumpers can be secured in a variety of ways to suit the end users needs. At minimum, jumpers can rest on cantilevers and pedestal support brackets, though you may desire additional wire management items for aesthetic purposes

Wire baskets

- Jumpers can rest in baskets, or be attached to the exterior of the basket using Velcro strips



Cable clamps

- While OFS does not supply this item, a cable clamp can be used to manage cables. This would attach the jumper directly to the bottom of the surface. **Note:** Additional jumper length may be needed if jumpers are not run in a straight line. Order cable clamp diameter size based on diameter of jumper and/or cables combined



PET wire manager

- PET trays are typically used for undersurface wire management, but they can also be mounted to the panel to manage power and data cables along the spine wall. Doing so allows you to completely conceal the jumper and data cables. **Note:** Additional jumper length may be needed
- Typically used along spine walls to cover jumpers along the panel that could be visible when a height adjustable table is in the raised position.

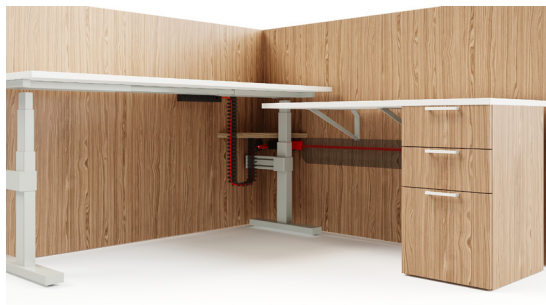

Electrical

Infeed planning - end of run

- When power starts at the end of a run, the most direct way to run power is in horseshoe type layout as indicated by the arrows in the below image
- The infeed will attach to the end power box, and the jumpers will carry on in a straight line, crossing to the other side of the station through the spine panel, and then continue back down the typical

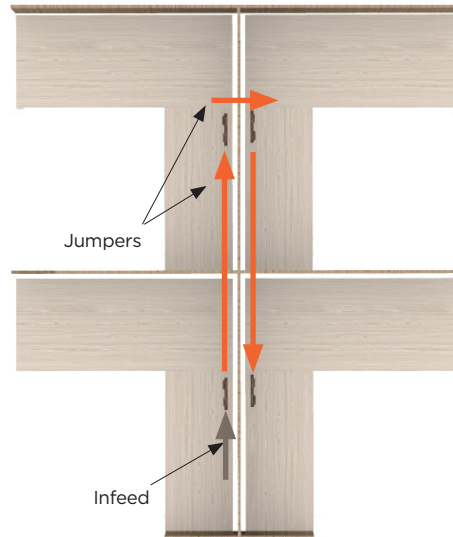

Infeed planning - middle of run

- When power starts at the middle of a run, from a floor core inside of the station, it is best to utilize an H block or Y block, and run the power jumpers to the power blocks as indicated by the arrows. **Note:** YCB5 connects directly to the power block
- When using an H block, the infeed will connect to one of the four connection points on the H block. A shorter jumper will connect the H block to the closest power block. A second jumper will connect the H block to the power block at the top of the station. From there, you will cross over to the next power box, and then connect the two power boxes with a longer jumper
- **Note:** Wire baskets or cable clamp should be used to help the jumper and power infeed attach cleanly under the worksurface

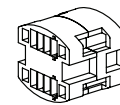
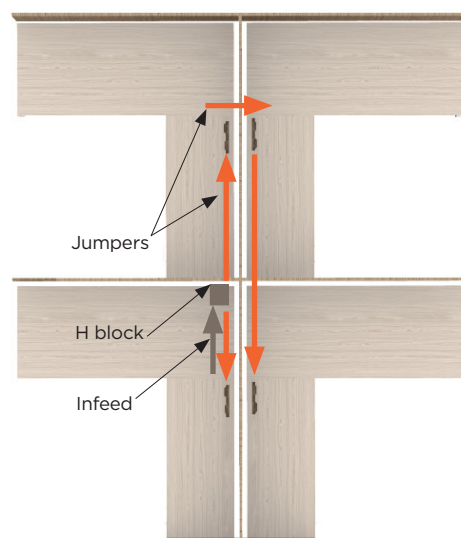

HCB - 2 circuit/4 wire



YCB5 - 3 circuit/5 wire



HCB2 - 4 circuit/8 wire

Electrical

Infeed management - floor core under pedestal

- When a floor core is located where a storage pedestal is to be placed, it is recommended to specify a low height pedestal on the 3.5" h metal legs. Extra infeed length can be coiled under the pedestal. **Note:** A 90° connector is recommended to be installed by the electrician when connecting the infeed to the floor core in this application

Floor core in middle of station

- When a floor core is located inside of the station where it will be viewed, a vertical wire manager is recommended to be used to cover the infeed and data cords that will run vertically from the floor core

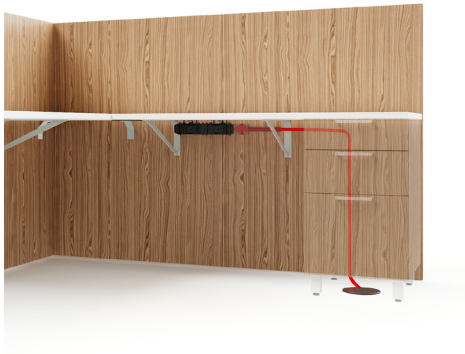

Floor core under pedestal



Floor core in middle of station

Vertical wire managers

- The following vertical wire managers can be used to conceal infeed and data cords that are visible inside of the station
 - WM-HA6: Fabric wire manager that secures around cords with Velcro strip
 - CMV-AL: Vertebra wire manager will only house data wires and small cords, infeed would need to be secured to the exterior of this wire manager
 - VCWM4 used for medium cabling
 - VCWM5 used for heavy duty cabling
- WM-HA6 can be cut in field if needed. CMV-AL, VCWM4 and VCWM5 connect to underside of worksurface

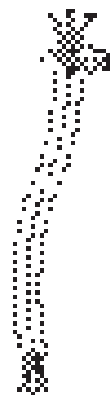

WM-HA6



CMV-AL

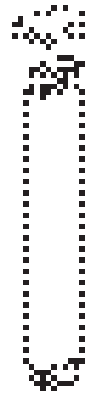

VCWM4



VCWM5

Electrical

Wiring diagrams

2 circuit / 4 wire power

20 Amp outlets (Circuit 1 and 2 only)

3 circuit / 5 wire power

20 Amp outlets (Circuit 1, 2, and 3 only)

4 circuit / 8 wire power

15 Amp outlets (Circuit 1, 2, 3, and 4. Circuit 4 is isolated and dedicated)

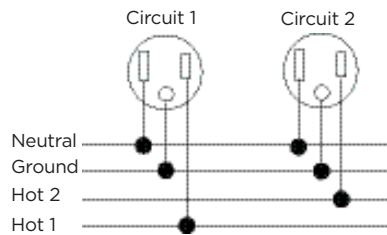

2 circuit / 4 wire power

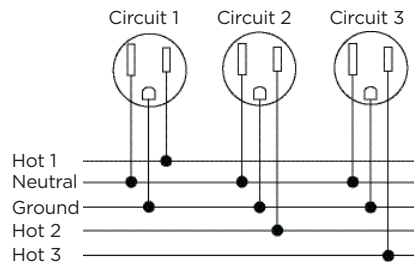

3 circuit / 5 wire power

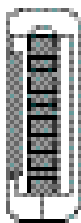

Gray	Neutral 2
White	Neutral 1
Green/yellow	Iso ground
Green	Ground
Pink	Hot 4
Blue	Hot 3
Red	Hot 2
Black	Hot 1

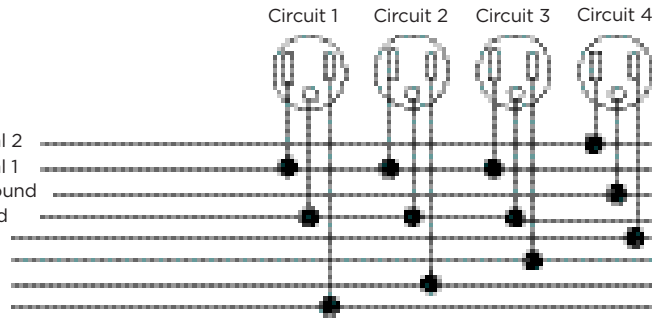

4 circuit / 8 wire power

Electrical

2 circuit / 4 wire power

Duplexes

- There is one type of power unit used for open plan applications, a single duplex (Circuit I or Circuit II) with connection points at each end for jumper or infeed connections
- A double block can be created by connecting two duplexes with a JC-1 jumper connector

Duplex bracket

- Duplexes are connected to the underside of the worksurface with a bracket (included)
- Duplexes sit flush to the underside of the worksurface

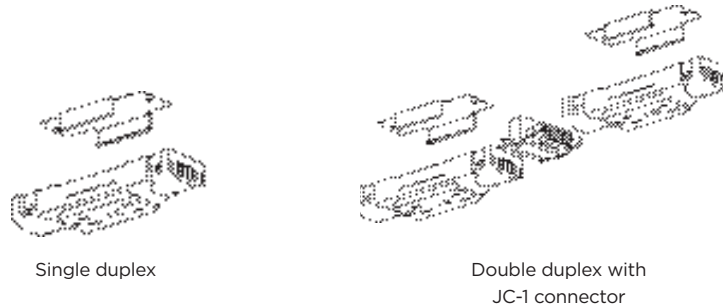

Single duplex

Double duplex with
JC-1 connector

Jumpers

- Jumpers come in lengths of: 12" w, 18" w, 24" w, 30" w, 36" w, 42" w, 48" w, 60" w, and 72" w

Jumper connector

- A HCB block connector allows junction for up to four jumpers, or three jumpers and an infeed
- **Note:** Jumper connector should be placed evenly between power boxes, to maintain consistent jumper lengths

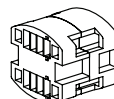
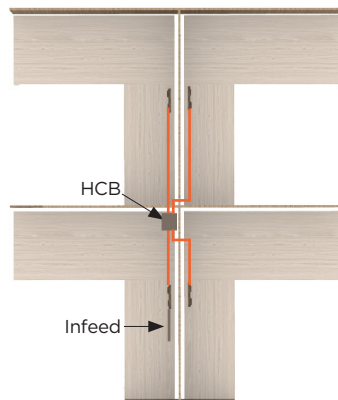

HCB

Electrical

3 circuit / 5 wire

Duplexes

- Duplexes are 20 amp circuits, UL listed
- Available in circuits I, II, and III

Power blocks

- Power block widths:
 - Single: 6"w
 - Double: 12"w
 - Extended double: 18"w, 24"w, 30"w
- When using 3 circuit / 5 wire electrical there are two types of power blocks used for open plan applications, a single and a double power block. Both blocks are double sided and the double power block comes in multiple lengths. A single power block will hold (2) duplex, a double power block will hold (4) duplexes.
- Power blocks are connected to the underside of a surface with a PBBKTA2 bracket. Duplexes then attach to the power blocks.
- **Note:** Duplex box is double sided, but does not require duplexes on both sides

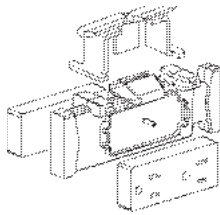

Single duplex box

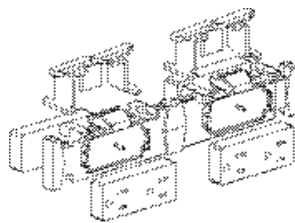

Double duplex box

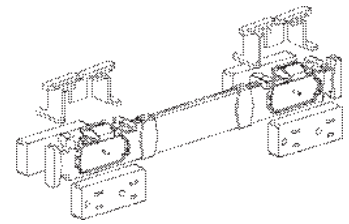

Double extended duplex box

Jumpers

- Jumpers come in lengths of: 12"w, 18"w, 24"w, 30"w, 36"w, 42"w, 48"w, 60"w, and 72"w

Jumper connector

- Jumper connectors are not available for 3 circuit / 5 wire systems. If longer spans are needed, utilize the extended duplex power block, or add an additional power block

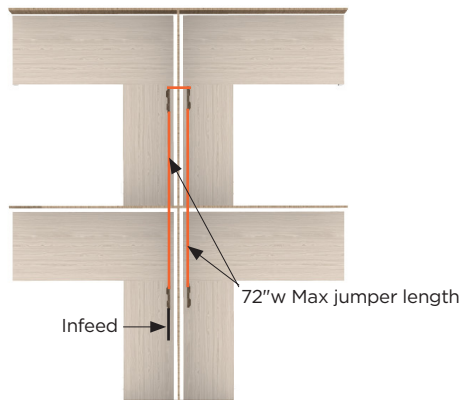

Electrical

4 circuit / 8 wire

Power blocks

- When using 4 circuit / 8 wire electrical, there are two types of power blocks used for open plan panel applications, a single half and a double half. A single half power block will hold (1) duplex, a double half power block will hold (2) duplexes
- **Note:** There are also single and double power blocks, which are double sided, but are not to be used along panels
- Power blocks are connected to the underside of a surface with a PBBKT1 bracket. Duplexes then attach to the power block



Single duplex box

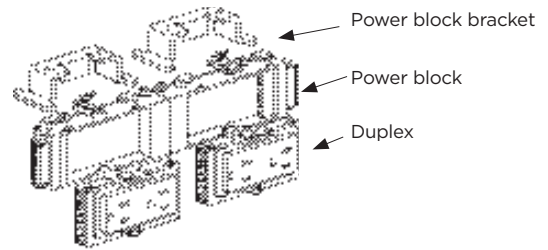

Double duplex box

Jumpers

- Jumpers come in varying lengths from 8”w to 84”w. When a span between two power blocks is greater than 84”w, two jumpers can be connected together using a JC-2 jumper connector
- A HCB2 block connector allows junction for up to four jumpers, or three jumpers and an infeed
- **Note:** Jumper connector should be placed evenly between power blocks, to maintain consistent jumper lengths

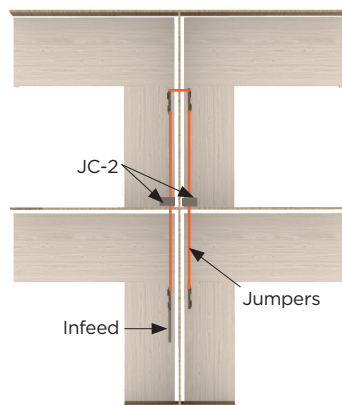

JC-2

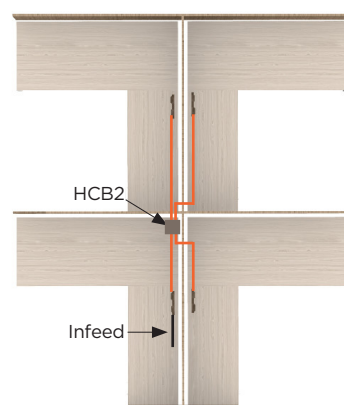

HCB2



Electrical

Chicago power

- OFS does not supply power components for areas that require Chicago power code. Chicago electricians wiring restrictions that require that all wiring and connections be supplied and connected by a licensed electrician
- A PWF3M120 infeed may be used if requested by the electrician
- Electrician supplied power/junction boxes can be installed directly to Staks work panels, at any height. Recommended installation would be along the floor, or just below the worksurface

New York City Code

- Infeeds available for all circuit systems
- Concealed power components are available under premium power

Title 24

- DPX8WCT duplexes. Duplex available as circuit I, II, III, or IV. (Circuit IV is isolated and dedicated)

Electrical

Data

- Staks offers a data box (DM1) that comes with a variety of openings to accommodate a variety of inserts
- As standard, we offer voice (RJ-5) and data (RJ-45) modules to work with these units. RJ-5 and RJ-45 would use FFF Insert
- Additional modules would be supplied by the specifier or end user
- This data box can be placed anywhere under a surface. We also offer modular desktop power units that can accommodate data ports
- As an alternative option, the end user may wish to supply their own data items. Because of the flexibility of Staks, they would also be able to place their own units anywhere along the underside of a Staks surface



DM1 top view

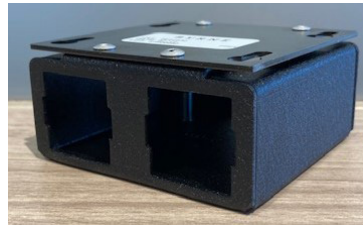

DM1 front view



DM1 back view



BBB

EEE

DDD

CCC

FFF

HHH

Filing capabilities

File capacity

- All OFS filing configurations meet standard file tab clearance of 1.25" above the file frame as recommended by our file frame suppliers
- **Note:** 24"w lateral file drawers available only as side-to-side filing. 30"w and 36"w lateral file drawers available as front-to-back or side-to-side filing

12"w pedestals

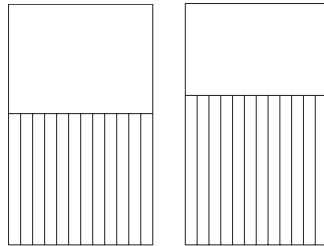

Letter side-to-side

Legal side-to-side

15.625"w pedestals

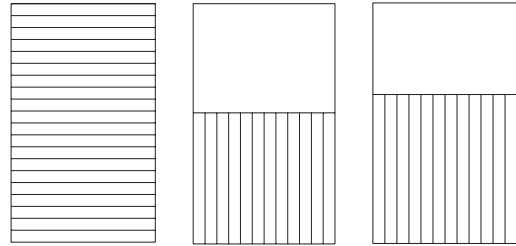

Letter front-to-back

Letter side-to-side

Legal side-to-side

Lateral files

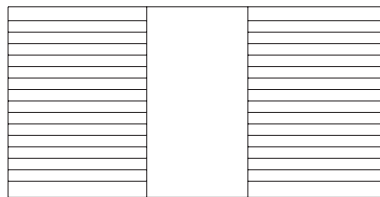

Letter double front-to-back

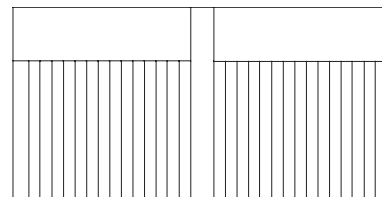

Letter double side-to-side

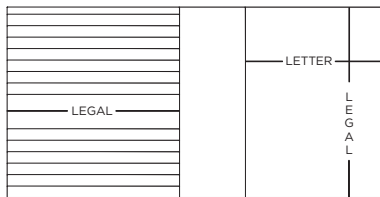

Legal front-to-back

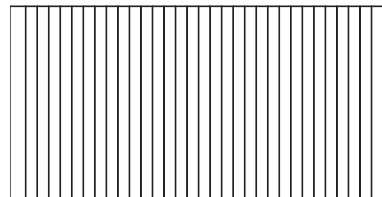

Legal side-to-side